

TXD SERIES ENGINEERING INFORMATION

The TXD-215 is a front-loaded low frequency loudspeaker enclosure designed to give bass and sub-bass reinforcement to TXD series two-way enclosures in a wide variety of live sound applications, as well as in fixed installations ranging from cafés, pubs, bars and restaurants to retail stores and houses of worship.

It consists of two 15" reflex-loaded low frequency drivers in an optimally tuned rectangular enclosure. The TXD-215 includes an internal low-pass crossover network which filters high frequency signals from the bass driver when used in conjunction with two-way enclosures such as the TXD-121 or TXD-151, enabling a full range system to be powered from a single amplifier channel without the need for external electronic crossovers.

The cabinet is constructed from 15mm (5/8") birch plywood, screwed and glued together for maximum rigidity, and is finished in TurboBlue™ semi-matt textured paint. Pole mount sockets are fitted on the top and sides of the cabinet to enable full range

cabinets to be mounted on optional 35mm poles. When used in a horizontal format the two side-mounted pole mounts allow two TXD-121 or TXD-151 full range enclosures to be mounted on top of a single TXD-215 bass enclosure to provide wider horizontal dispersion. Four recessed flush handles are provided for easy lifting and carrying and the cabinet is pre-drilled for optional T4 wheels. Four rubber feet are fitted to the bottom of the cabinet, and a grey powder-coated perforated steel mesh grille protects the drive units from damage.

M10 rigging points are provided on the top and rear of the cabinet to enable the TXD-215 to be suspended and angled in permanent installations using standard M10 shoulder eyebolts.

Two Neutrik Speakon NL4MP speaker connectors are located on the rear panel, providing input and parallel connections to additional TXD series cabinets.



FEATURES

- High efficiency**
- Rigging points**
- Passive crossover**
- Pole mount sockets**

APPLICATIONS

- Live sound**
- Mobile DJ**
- Fixed installations**

DIMENSIONS (HxWxD)	891mm x 550mm x 505mm (35.1" x 21.7" x 19.9")										
NET WEIGHT	47kg (103.4lbs)										
COMPONENTS	2 x 15" (381mm) LF drivers										
FREQUENCY RESPONSE¹	40Hz - 150Hz ±4dB										
POWER HANDLING	600 watts r.m.s., 1200 watts program Recommended amplifier power 1200 watts @ 4 ohms										
SENSITIVITY²	99dB, 1 watt @ 1 metre										
MAXIMUM SPL	127dB continuous ⁴ , 133dB peak ⁵										
CROSSOVER	12dB/octave low-pass at 150Hz										
NOMINAL IMPEDANCE	4 ohms										
CONSTRUCTION	15mm (5/8") birch plywood enclosure. Finished in TurboBlue™ semi-matt textured paint (optional black). Four recessed carrying handles. Pre-drilled for T4 wheels. Three integral pole mount sockets										
GRILLE	Heavy duty powder coated perforated steel mesh										
CONNECTORS	(2) Neutrik Speakon NL4MP, wired pin1+: positive, pin 1-: negative, pins 2+ and 2- N/C										
FLYING HARDWARE	(3) M10 internal threaded rigging points										
SPARES AND ACCESSORIES	<table border="0"> <tr> <td>LS-1523</td> <td>15" (381mm) LF loudspeaker</td> </tr> <tr> <td>RC-1523</td> <td>Recone kit for LS-1523</td> </tr> <tr> <td>T4 wheel kit</td> <td>Heavy duty wheels</td> </tr> <tr> <td>MG-215/X</td> <td>Metal grille</td> </tr> <tr> <td>PX-215/X</td> <td>Passive crossover network</td> </tr> </table>	LS-1523	15" (381mm) LF loudspeaker	RC-1523	Recone kit for LS-1523	T4 wheel kit	Heavy duty wheels	MG-215/X	Metal grille	PX-215/X	Passive crossover network
LS-1523	15" (381mm) LF loudspeaker										
RC-1523	Recone kit for LS-1523										
T4 wheel kit	Heavy duty wheels										
MG-215/X	Metal grille										
PX-215/X	Passive crossover network										

Notes

¹Measured on axis

²Average over stated bandwidth

³Average over stated bandwidth

⁴Unweighted diode-clipped pink noise. Measured in a half space environment

⁵Verified by subjective listening tests of familiar program material, before the onset of perceived signal degradation

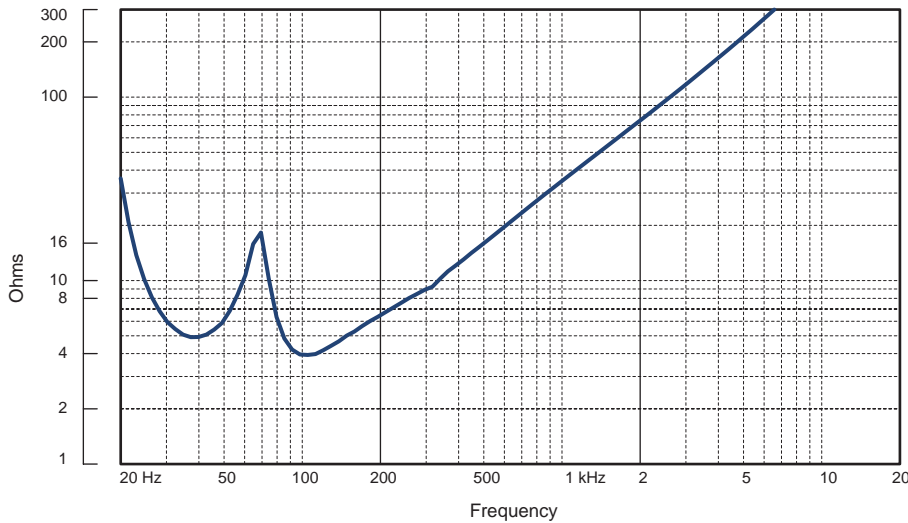
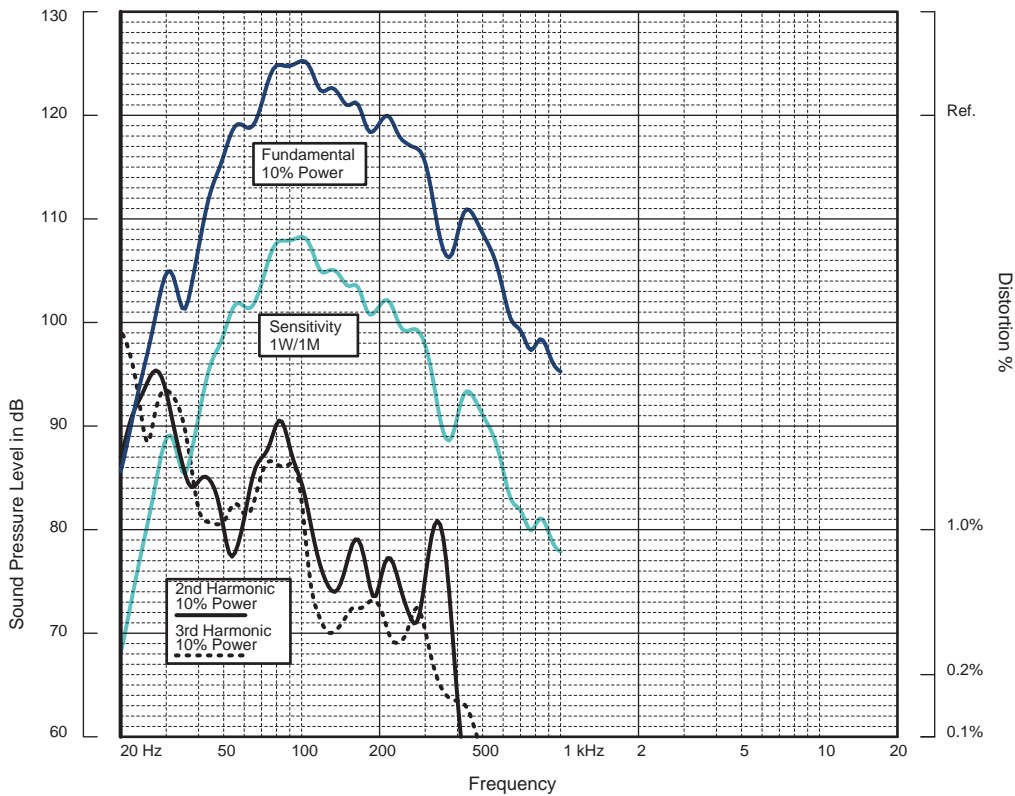

The cabinet is fitted with three internal M10 threaded rigging points on the top and rear which enable single enclosures to be permanently installed using M10 shoulder eyebolts with a minimum thread length of 20mm. Downward inclination of the enclosure is achieved by adjustment of the rear rigging point

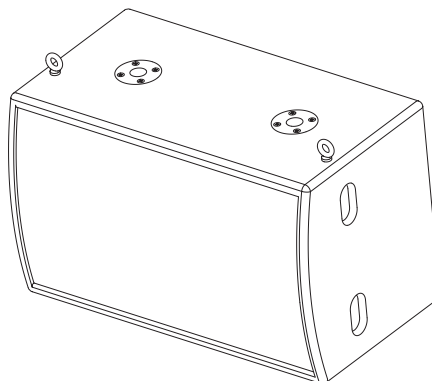

INSTALLATION AND RIGGING HARDWARE

**ARCHITECTURAL
& ENGINEER'S
SPECIFICATIONS**

The speaker shall be of the low frequency type consisting of two 15" (381mm) low frequency drivers. Performance specifications of a typical production unit shall meet or exceed the following: frequency response, measured with swept sine wave input, shall be flat within $\pm 4\text{dB}$ from 40Hz - 150Hz. Nominal impedance shall be 4 ohms. Power handling shall be 600 watts r.m.s., 1200 watts program. Sensitivity, measured with 1 watt input at 1 metre distance on axis, mean averaged over stated bandwidth, shall be 99dB. Maximum SPL (peak) measured with music program at stated amplifier input shall be 133dB. Dimensions: 891mmH x 550mmW x 505mmD (35.1"H x 21.7"W x 19.9"D). Weight: 47kg (103.4lbs). The loudspeaker system shall be the Turbosound TXD-215. No other loudspeaker shall be acceptable unless submitted data from an independent test laboratory verify that the above combined performance / size specifications are equalled or exceeded.

DIMENSIONS

