

S-PLAY



Contents

Safety	5
Package contents	5
Physical Features	6
Physical dimensions.....	7
Mounting Options	7
Software Features	8
Diagrams.....	8
Connector Pin-Out.....	8
FEMALE DMX (XLR5).....	8
MALE RS232 (DB9).....	8
Relay.....	9
GPIO.....	9
Wiring S-Play	9
S-Play to Playback to DMX systems	10
S-Play to Playback to Pixel systems	11

S-Play to integrate with Octo.....	12
S-Play application diagram.....	13
Getting Started.....	14
The LCD Menu.....	14
Controls.....	14
Layout.....	14
Home screen.....	15
Cues screen.....	15
Playlist screen.....	15
Settings screen.....	15
Web interface.....	16
Home.....	17
Cue Library.....	18
Events.....	18
Triggers.....	19
Playlist.....	19
Scheduler.....	20
Settings.....	21
Status.....	22
Backup.....	23
Record.....	24
Static Cue.....	24
Dynamic Cue.....	25
Manual Control.....	26
Art-Net Triggering.....	27
Playback.....	28
Preview Cue.....	28
Playlists.....	28
Playlist Page Layout.....	29
Created Playlists.....	30
Global Playlist Control.....	30
List of Playlists.....	30
Available cues and controls.....	31

Playlist attributes	31
Playlist Settings.....	31
Playlist timeline and Media tracks.....	32
Event and Trigger tracks	33
Example Playlist.....	33
Control	34
Events.....	34
RS232.....	34
Art-Net.....	34
DMX.....	34
sACN	35
Relay.....	35
Triggers.....	36
OSC	36
RS232.....	36
DMX.....	37
Digital Input.....	37
Art-Net.....	37
sACN	38
Schedule.....	38
Created Schedules.....	39
List of Schedules.....	40
Schedule name	40
Selected playlist.....	40
Start condition.....	40
End condition.....	41
Frequency type	41
Per Second.....	41
Per Minute	42
Hourly	42
Daily.....	42
Weekly.....	42
Monthly.....	43

Yearly	43
Astronomical.....	43
Setup	43
Changing the Network Settings.....	43
Changing the Network Settings Using LCD Interface	43
Change IP Using Web Interface	45
S-Play Output.....	46
Art-Net output configuration.....	46
sACN output configuration.....	47
DMX output configuration	47
Change Date/Time and Location	47
Factory Reset.....	48
LCD.....	48
Via web interface	48
Backup	49
Restore	49
Storage.....	50
Select Storage.....	50
Export Playback Data	51
Locking the unit and user management.....	52
How to use the Lock feature	52
User information and passwords	53
Status	54
Network Information.....	54
Output Information	54
System Information.....	54
Software Information.....	54
Network Discovery	55
Built-In IP Address Discovery.....	55
Find Device IP Address from NMU	55
Specifications.....	56
Tips and Tricks.....	57
Network Recommendations.....	57

Unable to connect to S-Play IP address, what now?	57
My recorded sequence contains parts of a different recording inside it	57
Using Motion sensors with S-Play	58
Diagram	58
Steps	58

Safety

- This unit is intended for indoor use only.
- Do not expose this device to rain or moisture, doing this will void the warranty.
- Make all the connections before you plug in the mains power
- Do not remove the cover, there are no user-serviceable components inside.
- Never plug this unit into a dimmer pack
- Ensure proper earth connections
- Always be sure to mount this unit in an area that will allow proper ventilation. Allow about 6" (20 cm) between this device and a wall.
- Power-supply cords should be routed so that they are not likely to be walked on or pinched by items placed upon or against them, pay particular attention to the point they enter and exit the unit.

Package contents

When you open the packaging, you should find these items in the box:

- S-Play (70092)
- 2m cat5 cable (79102)
- 1RU mount kit (79105)
- 1 X 12V PSU adaptor with international plugs
- ReadMe Card

Physical Features

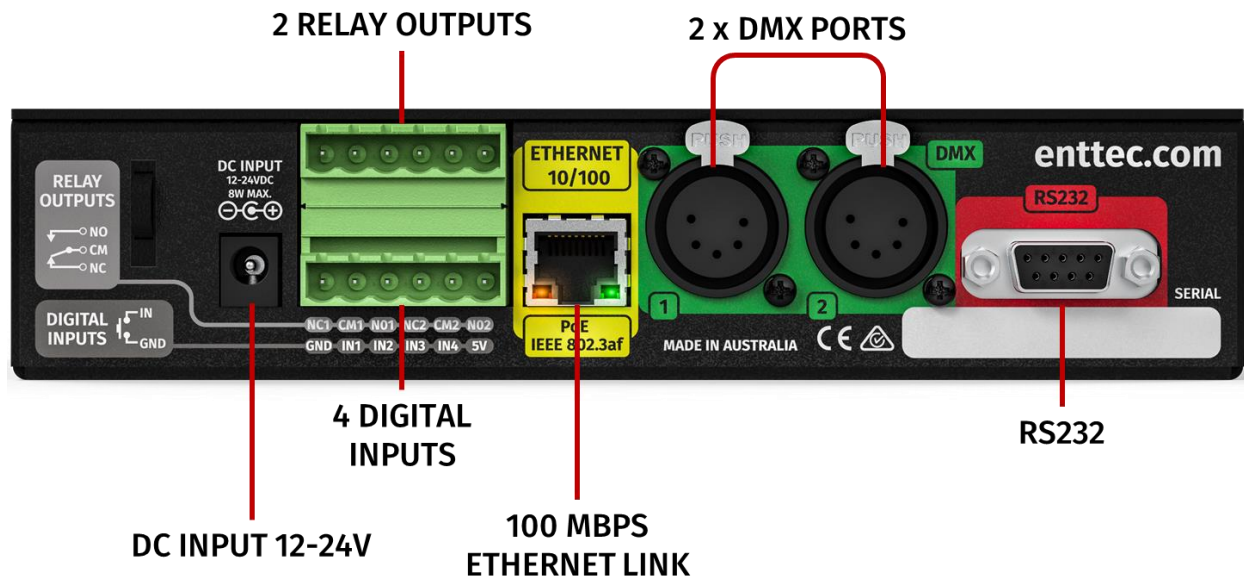

- 1RU Size
- Two bi-directional 5 Pin female DMX Ports
- Colour TFT LCD screen (160x128)
- Navigation LCD menu buttons
- 1 x USB port
- DC Input (12V to 24V)
- MicroSD card storage (Class 10 40/10 Mb/s Read/write performance)
- 100 Mbps Ethernet link
- 4 Digital Inputs (GPIO)
- 2 Relay outputs (NC, NO, COM)
- Solid-state design

Physical dimensions

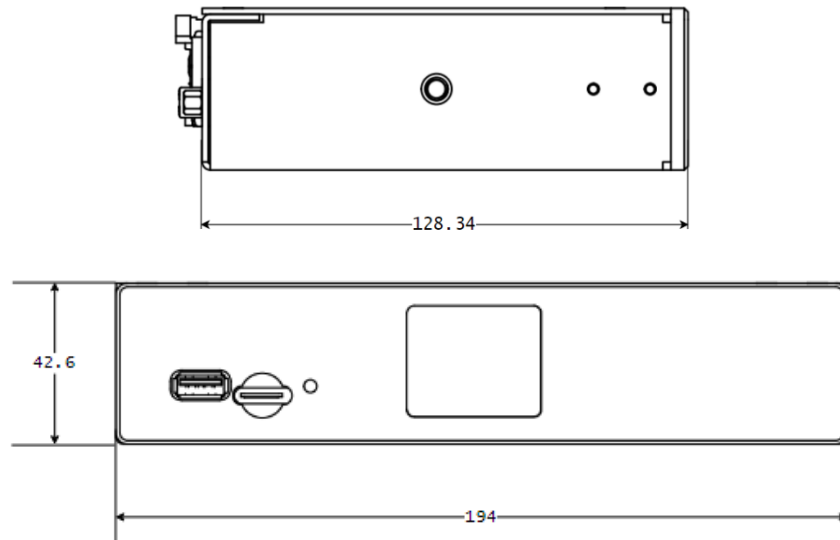

Mounting Options

Provided standard, 1RU mount kit (pn: 79105)

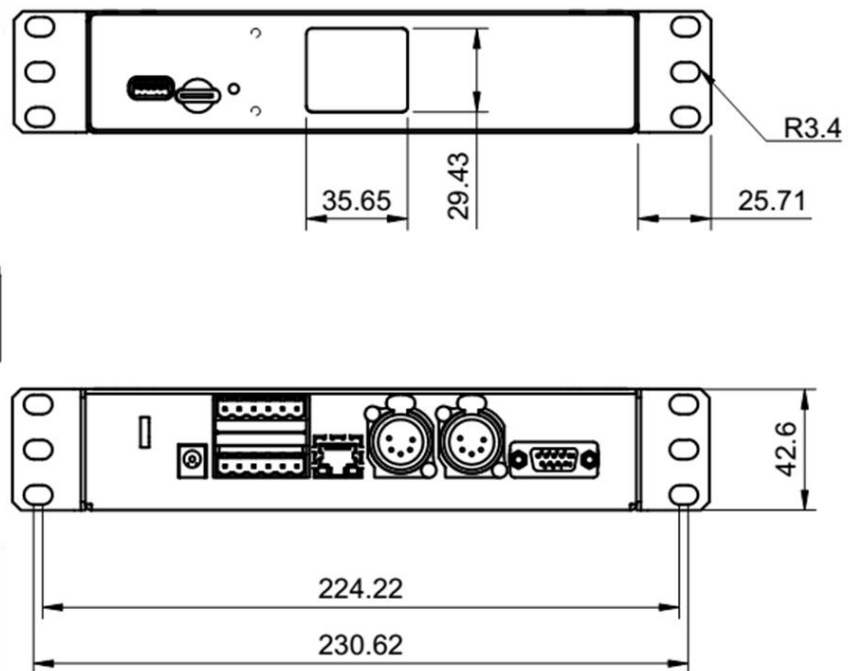
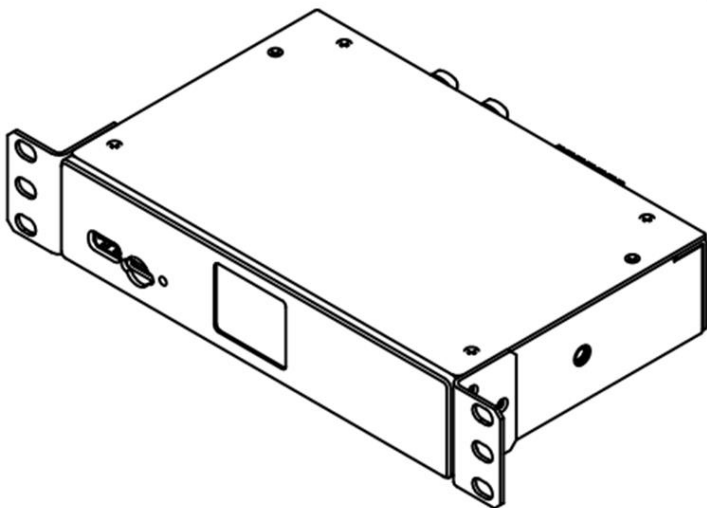

Notes

All dimensions are in millimetres (mm)

Software Features

- Supports DMX512
- Supports DMX over the network protocols:
 - DMX
 - Art-Net
 - sACN
- 2 Universe DMX output or input
- 16 Universe Art-Net and sACN output or input
- Create / edit DMX Scenes (static cue)
- Create / edit DMX Presets (dynamic cue)
- Preview cues being created
- Monitor the DMX values of cues being made
- Make playlists from DMX Presets (dynamic cue)
- Make live recordings using DMX/Art-Net/sACN
- Schedule Playlist
- Mapping different streams and protocols to different ports
- HTP merge between cues and Playlists
- Fade to black on Stop
- Hold last value on Pause
- Remote trigger options: RS232, HTTP, OSC, GPIO, ArtNet, sACN and DMX
- Configurable output refresh rate. (Max 60FPS)
- Lock usability for a registered user

Diagrams

Connector Pin-Out

FEMALE DMX (XLR5)

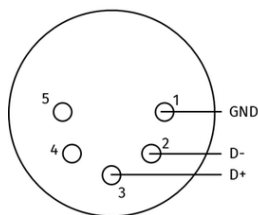

PIN	CONNECTION
1	GND
2	DATA -
3	DATA +
4	NC
5	NC

MALE RS232 (DB9)

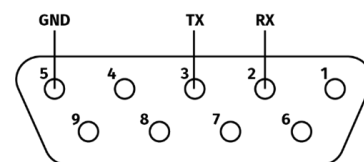

PIN	CONNECTION
1	NC
2	RX
3	TX
4	NC
5	GND
6	NC
7	NC
8	NC
9	NC

Relay

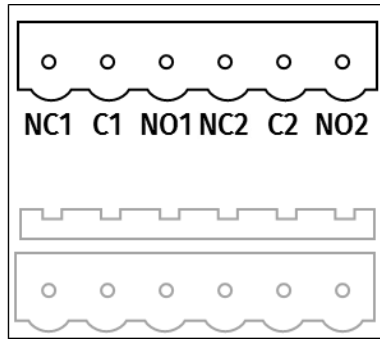

GPIO

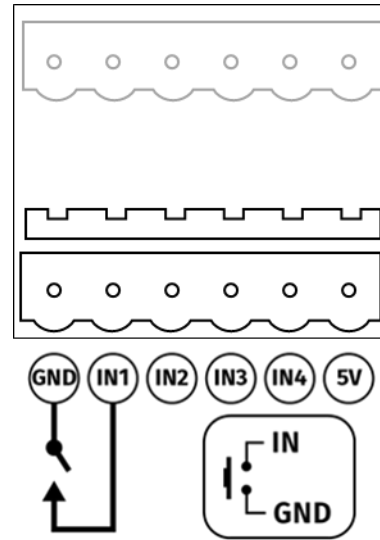

Wiring S-Play

USB

USE A USB DRIVE OR SD CARD TO BACKUP AND RESTORE FILES
SELECT BETWEEN INTERNAL AND EXTERNAL MEMORY - SD CARD

USER INTERFACE

LCD SCREEN MENU AND NAVIGATION BUTTONS TO ACCESS PLAYLISTS AND CUES

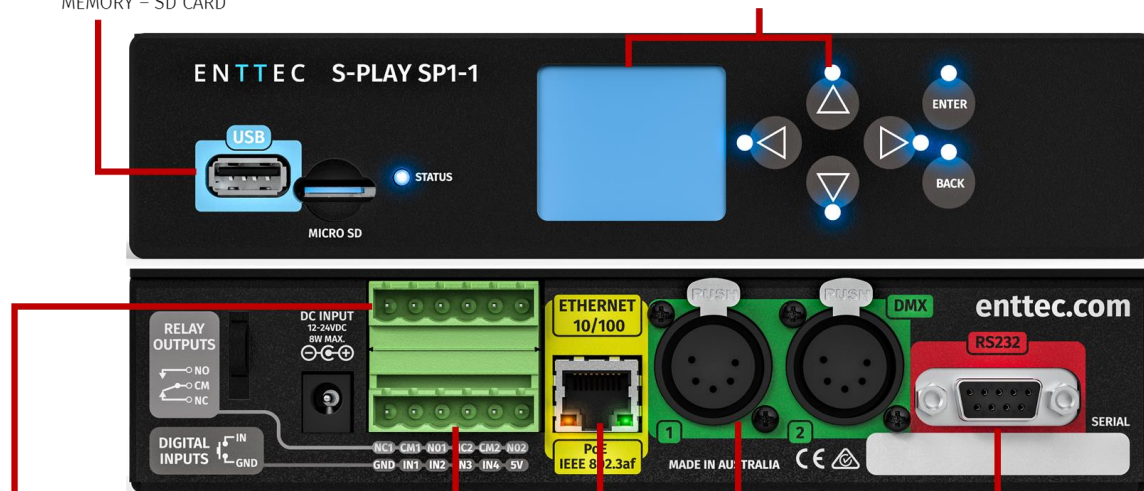

DIGITAL INPUT

FOUR DIGITAL INPUTS TO RECEIVE TRIGGERS FROM DEVICES LIKE SENSORS, PRESSURE PADS, SWITCHES, AMONG OTHERS

ETHERNET

ARTNET, SACN SUPPORT
OSC API

DMX IN-OUT

RECORD, PLAYBACK AND TRIGGER VIA DMX

RS232

USE RS232 COMPATIBLE DEVICES TO SEND AND RECEIVE TRIGGERS

RELAY

TWO RELAY OUTPUTS TO SEND TRIGGERS TO THIRD PARTY DEVICES

WEB INTERFACE

USE THE WEB INTERFACE TO CREATE PLAYLISTS, RECORD CUES AND ACCESS FULL FUNCTIONALITY OF THE UNIT

S-Play to Playback to DMX systems

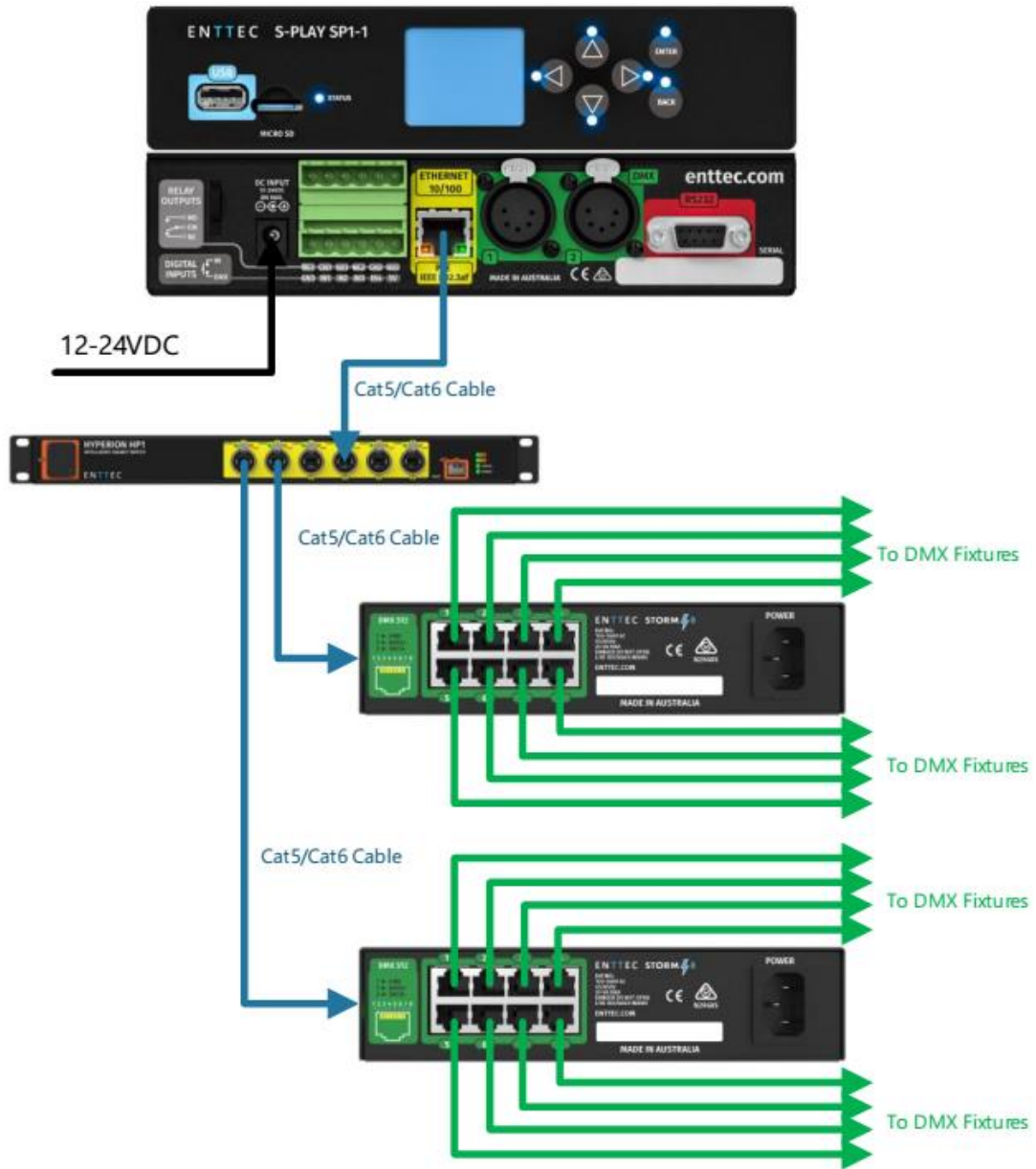

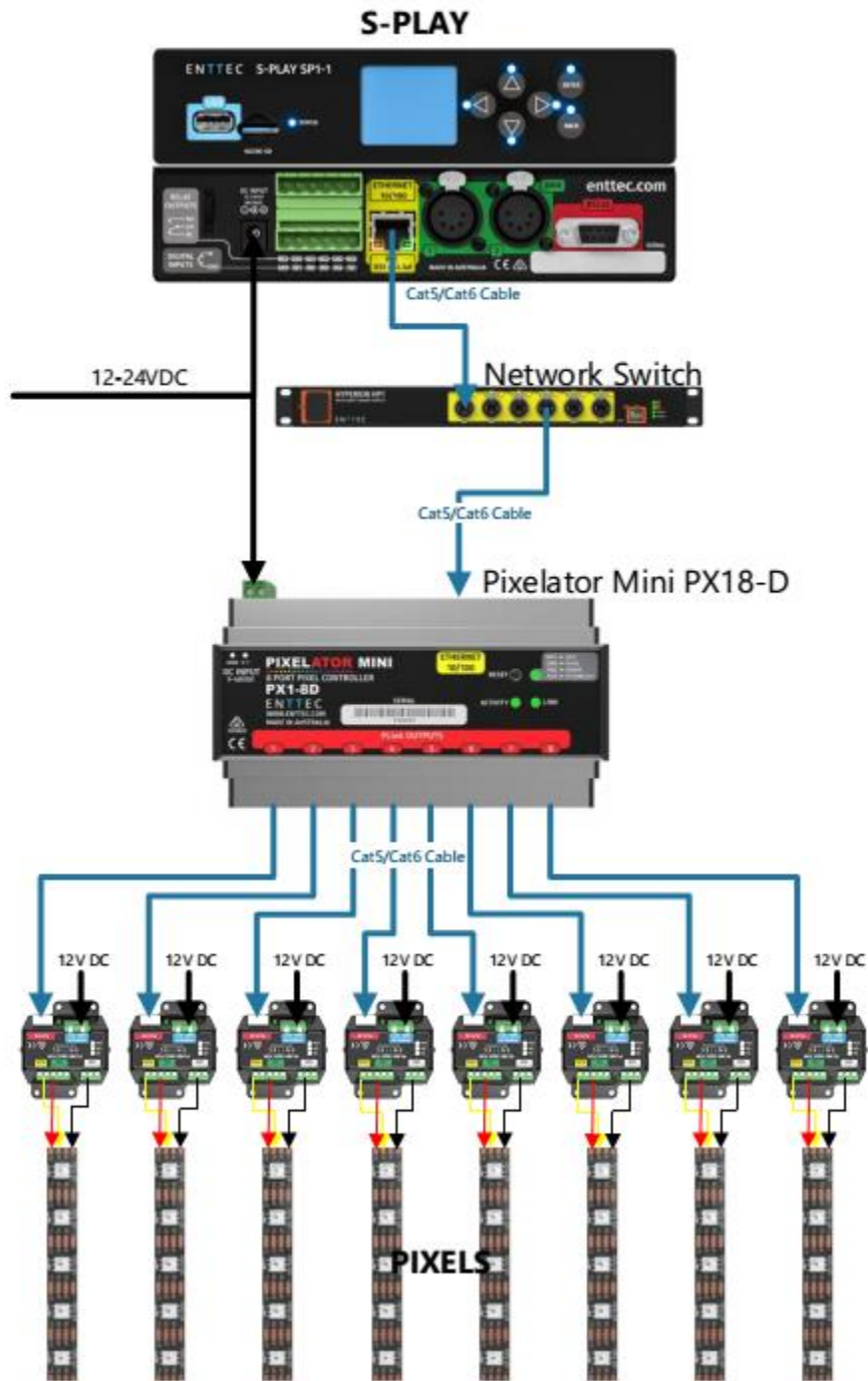

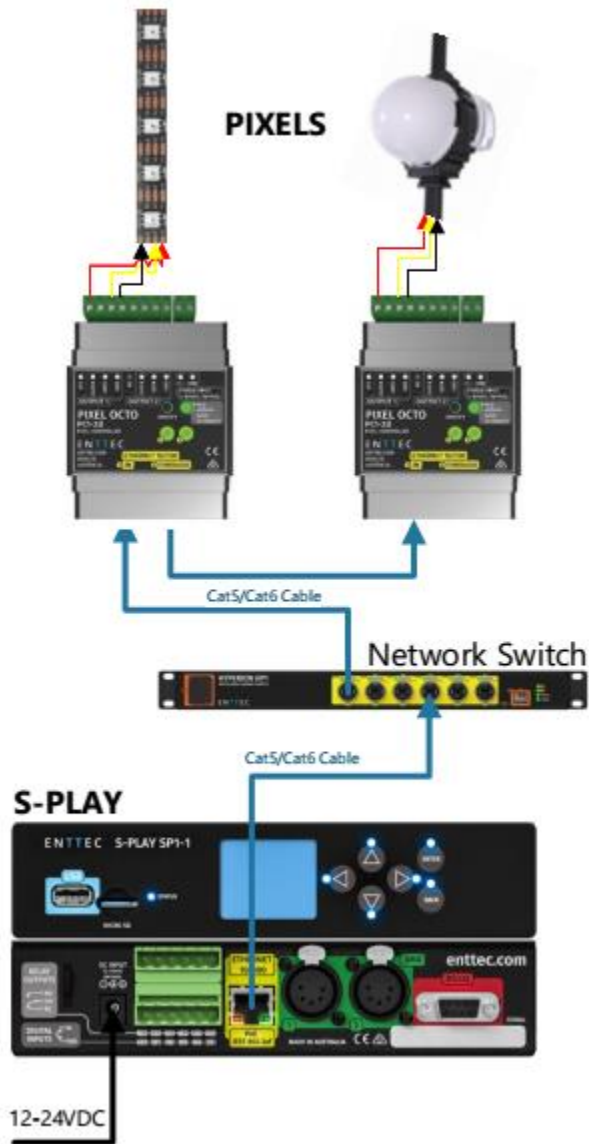

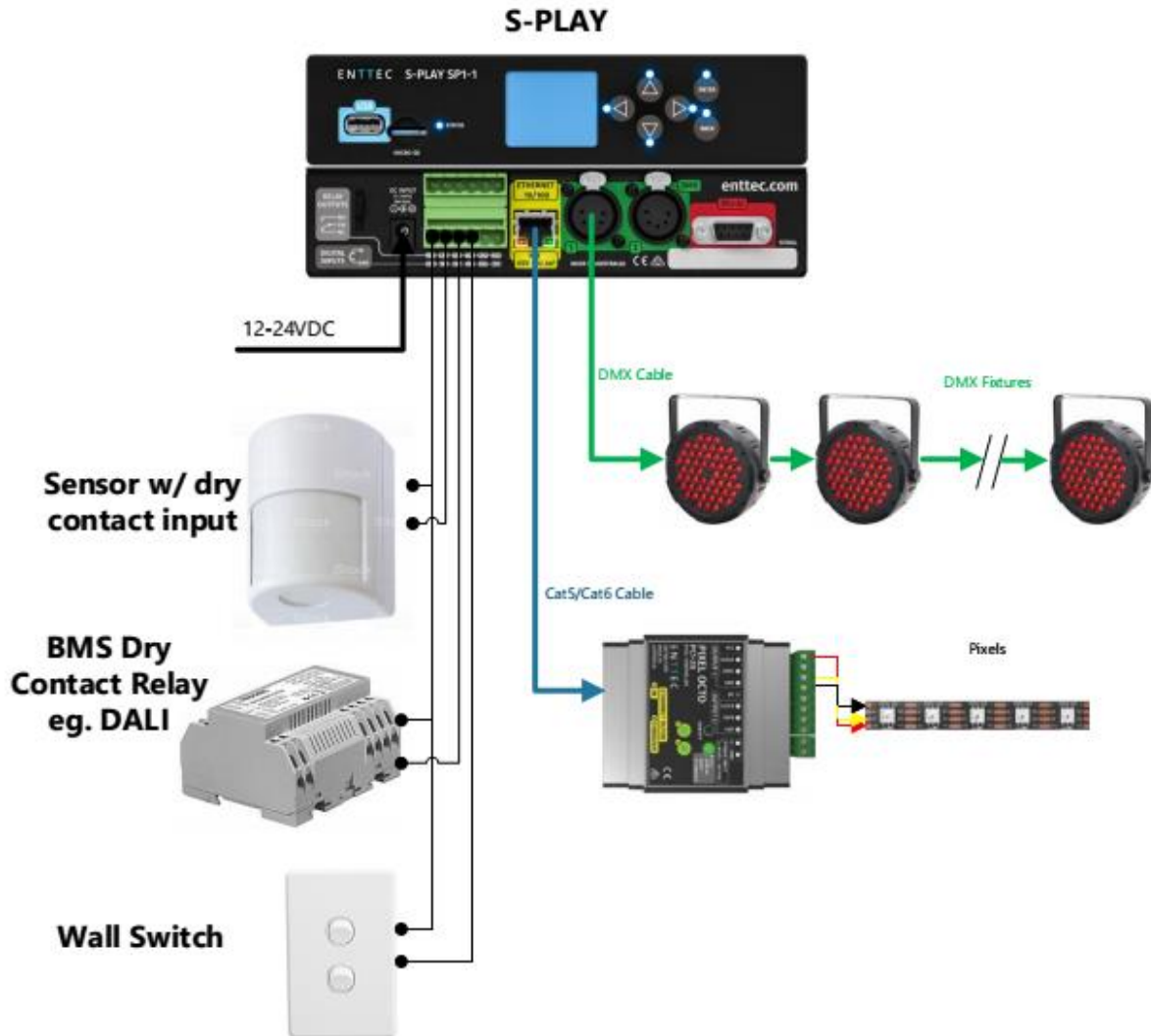

Getting Started

Right out of the box, the S-Play is factory configured to:

- Act as a DHCP node, so you can plug it into your existing router, and it's good to go
- Output to DMX ports
- NTP to update the date and time based on the selected time zone in settings

To begin your installation please follow these steps:

- Unpack the unit from the box. Inspect the S-Play for any damage that might have occurred in shipping and verify that it looks to be in good condition before plugging it into power.
- S-Play occupies 1RU, you will need to attach the mounting bracket kit included in the box
- Using a Cat5, Cat5e or Cat6 cable, connect the S-Play to an Ethernet Network
- If the unit is connected to a compatible PoE (IEEE 802.3aF) router or switch skip this step. Otherwise, use the provided AC/DC power adapter to power up the unit
- When the unit is on, you will be able to see its IP address on the LCD Panel. The IP address will be assigned by the network, if connected to a DHCP network, or will go to the default static IP. This IP address will let you connect with the unit's web interface

The LCD Menu

Controls

- **Direction arrows** – can be used to move between menu tabs and increase or decrease the value in the field with numbers such as IP address
- **Back**- Used to return to the main menu from a sub-menu
- **Enter** - Used to move down to a menu, access sub-menu options, set a numerical value or select options

Layout

NAVIGATION
TABS

SELECTED
SCREEN



Home screen

The home screen displays the following:

- Current date and time
- Device IP Address
- Device Name
- Playlist Status
- Lock screen
- Playlist control
- Brightness control

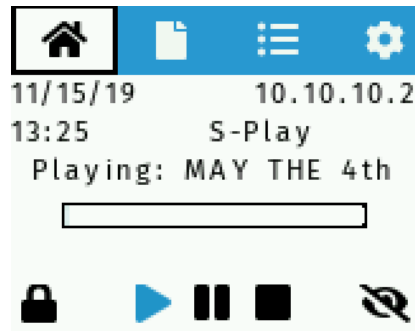

Cues screen

The cue screen allows the user the following:

- Navigate cues
- Preview cues
- Stop current previewing cues



Playlist screen

The playlist screen allows the user the following:

- Navigate playlists
- Play, pause and stop playlists
- Monitor playlist status



Settings screen

The settings screen allows the user the following:

- Display system status
- Change network specifications
- Display time and date
- Restore to factory defaults

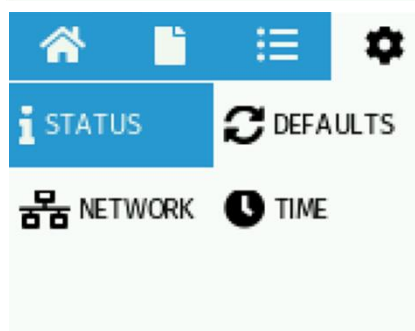

Web interface

S-Play can be configured and controlled through a web browser on a computer, located on the same Local Area Network as the device. Either click on the underlined URL displayed on NMU or type the IP address (as detected by NMU e.g. 10.10.3.156) into the web browser to access the web interface.



The pages are:

- Home
- Cue Library
- Events
- Triggers
- Playlists
- Scheduler
- Settings
- Status
- Backup

Home

The home page displays the following:

- Created Playlists:
 - Play, Pause, Stop and control playlists intensity
- Created Schedules:
 - Activate and Pause schedules

Playlists

No playlists stored. To create a new playlist click [here](#)

Schedulers

No registered Schedules.

Cue Library

Cue library consists of a list of 256 cues, which can either be static or dynamic. A static cue is a snapshot of up to 16 universes of data captured at a given time instance. A dynamic cue is multiple snapshots of up to 16 universes of data captured at a given time duration.

The cue library page allows the user the following:

- Access all recorded cues
- Preview and stop cues

ENTTEC

EN CN Login 

Home **Cue Library** Events Triggers Playlists Scheduler Settings Status Backup Nov 12 2019 16:00:49 PM

Show Cues

ID	Name	Type	Duration
1	Cue 001	Static	0.0
2	Cue 002	Static	0.0
3	Cue 003	Static	0.0
4	Cue 004	Static	0.0
5	Cue 005	Static	0.0
6	Cue 006	Static	0.0

Please select a cue to begin editing

- 256 Cues to choose from.
- To see more cues, use Previous and Next button at the bottom, or select number of Cues shown from top.
- Order by name, number or type (Click on title to order)
- Search by cue name or ID to filter the cues
- Select the cue, and more options will appear in this area to edit Cue.
- A cue can be either Static (DMX scene) or Dynamic (DMX recording)
- To save the cue either Edit Scene or Record

Events

The events page allows the user the following:

- Access all event options
- Create, edit and delete events

ENTTEC

EN CN Login 

Home Cue Library **Events** Triggers Playlists Scheduler Settings Status Backup Nov 12 2019 16:01:11 PM

Show Controls

ID	Name	Protocol
1	Event 000	N/A
2	Event 001	N/A
3	Event 002	N/A
4	Event 003	N/A
5	Event 004	N/A
6	Event 005	N/A

Events are commands that are sent from S-Play using the desired protocol.

- 128 Events entries to configure
- To see more events, use the navigation buttons on the bottom of the page
- Click the name of the column to sort the list
- Search by event name, protocol type or event ID
- Click on the event row to display options
- Once saved, you can use the events in the Playlist Page.

Triggers

The triggers page allows the user the following:

- Access all trigger options
- Create, edit and delete triggers

Playlist

The playlist page allows the user the following:

- Access all playlists
- Play and stop playlists
- Delete playlist
- Create and Edit Playlists

The screenshot displays the ENTTEC web interface. At the top, the logo 'ENTTEC' is visible on the left, and 'EN CN Login' with a lock icon is on the right. Below the logo is a navigation menu with items: Home, Cue Library, Events, Triggers, **Playlists**, Scheduler, Settings, Status, Backup. The date and time 'Nov 12 2019 16:01:36 PM' are shown on the right. The main content area has a header 'All Playlists' with play and stop icons, and a 'Display' dropdown set to '30' and 'Pages' showing '1 / 0'. Below this is a 'Create New Playlist' button and a 'Search items...' input field. The main content is divided into four colored tabs: 'Static cue' (blue), 'Dynamic cue' (dark blue), 'Events' (green), and 'Triggers' (orange). To the right is a 'Playlist Attribute' panel with the following fields: Name (playlist), Priority (100), Loop (Infinity), Group (0), and Start Up Trigger (No Trigger). Below the tabs is a control bar with play, stop, and search icons, and a timer showing '00:00:00 / 00:00:00'. The main area is a table with columns for time (00:00, 05:00, 10:00, 15:00) and rows for Cue Track (four rows, each with a 100% volume icon), Event, and Triggers. At the bottom, a footer contains '© 2019 ENTTEC | Enttec Web | Contact us'.

Scheduler

The scheduler page allows the user the following:



- Access all schedules
- Play and pause schedules
- Monitor status of the schedule
- Create and edit schedules

No Registered Schedules

[Create New Scheduler](#) **Schedule Name:**

Select Playlist: **Loop:** 

Start:  **Time:**

End:   **After:** **Repetitions**

Frequency Type: Per Second Per Minute Hourly Daily Weekly Monthly Yearly Astronomical

Every **Hour(s)** 

[Save Scheduler](#) [Delete](#)

© 2019 ENTTEC | [Enttec Web](#) | [Contact us](#)

Settings

The settings page allows the user the following:

- Set S-Play outputs
- Configure Art-Net and sACN output universes and destination IP
- Configure refresh rate
- Configure DMX output port
- Set date, time and location
- Change Network configuration
- Reset to factory defaults
- Update firmware

Status

The status page displays the following:

- The network information of the device
- The current output protocols
- System information including:
 - System status
 - Playlist activity
 - CPU status
 - Storage status
 - Device name
 - System uptime
 - Hardware ID
- Software version information
 - Firmware version

Network Information

IP Address:	10.10.3.156
Subnet Mask:	255.255.255.0
Broadcast Address:	10.10.3.255
Serial No. / Mac Address:	00:50:C2:08:07:A7

Output Information

	Universe 1	Universe 2
Protocol	DMX	DMX
Universe	1	2
IP Address	NA	NA

System Information

System Status:	✔ STARTED STOP ENGINE REBOOT
Activity:	No Playlist is Playing
CPU Status:	Load: 8.4 % Temp: 49.1 °C
Disk Space:	<div style="display: flex; align-items: center;"> <div style="width: 100px; height: 10px; background-color: #007bff; border: 1px solid #007bff; margin-right: 5px;">5.10 % used</div> <div style="width: 700px; height: 10px; background-color: #e9ecef; border: 1px solid #e9ecef; margin-right: 5px;"></div> <div style="font-size: 0.8em; margin-left: 5px;">7.40 GB free out of 7.80 GB</div> </div>
System Name:	S-PLAY
System Uptime:	8 minutes
Hardware ID:	165166100581147c





Software Information

Software version:	06112019-910 (updated: 06/11/2019)
DMX driver version:	version: 1.4

Backup

The backup page allows the user the following:

- Settings backup
- Settings restore
- Storage location select
- Playback export

<h3>Settings Backup </h3> <p>Note! Preserves all the general settings of your S-Play that are not recordings. This backup file can be used to restore later.</p> <p>Warning! recorded cue files are not included, please either use FTP, or a USB thumb-drive and use front LCD to backup recorded cues.</p> <p>Backup Settings</p>	<h3>Settings Restore </h3> <p>Note! Please make sure you are using the correct file For example: <code>backup_IP_Address.sbak</code></p> <p>Warning! This will REPLACE all options, network settings & cue/playlist configurations on this unit.</p> <p>internal <input type="text"/></p> <p>Browse Restore Settings</p>
<h3>Select Storage </h3> <p>Note! Change storage which stores all cues, playlists, schedules and settings.</p> <p>internal <input type="text"/></p> <p>Select Storage</p>	<h3>Export Playback Data </h3> <p>Note! Export data from one storage to another replacing previous playback data on target storage</p> <p>From: internal <input type="text"/></p> <p>To: sd <input type="text"/></p> <p>Export Storage</p>

Record

To record Cues, select any cue in the library as shown in the image below.

S-Play previews a recording on the output ports set in settings. To avoid issues with the frames being recorded, make sure the output and the input ports and universes are not the same.

i.e. if recording from DMX, the output set in settings shouldn't be DMX. Once the recording is done, DMX output can be set again.

The screenshot shows the ENTTEC web interface. At the top left is the ENTTEC logo. On the right, there are links for 'EN', 'CN', 'Login', and a lock icon. Below the logo is a navigation menu with 'Home', 'Cue Library' (highlighted), 'Events', 'Triggers', 'Playlists', 'Scheduler', 'Settings', 'Status', and 'Backup'. The date and time 'Nov 13 2019 08:31:22 AM' are displayed on the right. The main content area is divided into two parts. On the left is a table of cues with columns for ID, Name, Type, and Duration. On the right is a form for editing a cue, with fields for 'Cue Name' (set to 'Cue 001') and 'Cue Type' (set to 'Static Scene'), and buttons for 'Edit Scene' and 'Clear Scene'.

ID	Name	Type	Duration
1	Cue 001	Static	0.0
2	Cue 002	Static	0.0
3	Cue 003	Static	0.0
4	Cue 004	Static	0.0

Select the cue type to be recorded:

- Static
- Dynamic

Static Cue

1. Select Static Scene as the cue type
2. Press edit scene button
3. Provide cue name to aid identification
4. Select one of the following options for data capture:
 1. Snap DMX (up to 2 Universes / 1024 Channels)
 2. Snap Art-Net (up to 16 Universes / 8192 Channels)
 3. Snap sACN (up to 16 Universes / 8192 Channels)
5. Specify the universes for capturing data
6. Once the option for capturing is selected, press on the capture button to take a snapshot of data at a specific time.

Toggle all inputs – Selects all input universes

Save scene - used to save the cue created

Close - Close edit window without saving

Preview – Observe the capture using DMX ports. This will stop any current playbacks

Stop Preview – Stop output of captured data through DMX ports

N.B. Sometimes not all universes are captured at a time because of the inconsistency of network packets order and S-Play's capturing logic which waits just for the selected number of frames (equal to number active universes).

The DMX values captured will be shown for the corresponding universe, as shown in the image

DMX Scene Editor ✕

Cue Name: Toggle All Inputs

Snap DMX
Snap Art-Net
Snap sACN
SET THRU @
Set DMX
Capture

In 1:
In 2:
In 3:
In 4:
In 5:
In 6:
In 7:
In 8:
In 9:
In 10:
In 11:
In 12:
In 13:
In 14:
In 15:
In 16:

In 1	In 2	In 3	In 4	In 5	In 6	In 7	In 8	In 9	In 10	In 11	In 12	In 13	In 14	In 15	In 16
255	245	251	255	245	251	255	245	251	255	245	251	255	245	251	255
251	255	245	251	255	245	251	255	245	251	255	245	251	255	245	251
245	251	255	245	251	255	245	251	255	245	251	255	245	251	255	245
255	245	251	255	245	251	255	245	251	255	245	251	255	245	251	255
251	255	245	251	255	245	251	255	245	251	255	245	251	255	245	251
245	251	255	245	251	255	245	251	255	245	251	255	245	251	255	245
255	245	251	255	245	251	255	245	251	255	245	251	255	245	251	255
251	255	245	251	255	245	251	255	245	251	255	245	251	255	245	251
245	251	255	245	251	255	245	251	255	245	251	255	245	251	255	245
255	245	251	255	245	251	255	245	251	255	245	251	255	245	251	255
251	255	245	251	255	245	251	255	245	251	255	245	251	255	245	251
245	251	255	245	251	255	245	251	255	245	251	255	245	251	255	245
255	245	251	255	245	251	255	245	251	255	245	251	255	245	251	255
251	255	245	251	255	245	251	255	245	251	255	245	251	255	245	251
245	251	255	245	251	255	245	251	255	245	251	255	245	251	255	245
255	245	251	255	245	251	255	245	251	255	245	251	255	245	251	255
251	255	245	251	255	245	251	255	245	251	255	245	251	255	245	251
245	251	255	245	251	255	245	251	255	245	251	255	245	251	255	245
255	245	251	255	245	251	255	245	251	255	245	251	255	245	251	255
251	255	245	251	255	245	251	255	245	251	255	245	251	255	245	251
245	251	255	245	251	255	245	251	255	245	251	255	245	251	255	245
255	245	251	255	245	251	255	245	251	255	245	251	255	245	251	255

✓ Save Scene
✕ Close
👁 Preview
✕ Stop Preview

Dynamic Cue

Dynamic cues recording can be started manually or by sending an Art-Net trigger

N.B. During Art-Net recording check if no active Art-Net output is broadcasting to eliminate frames loopback, which leads to the incorrect recording.

Manual Control

1. Select Dynamic Scene as the cue type
2. Select "Manually" from the Rec. Control option
3. Press edit record button
4. Provide cue name to aid identification
5. Select one of the following options for data capture:
 1. Snap DMX (up to 2 Universes / 1024 Channels)
 2. Snap Art-Net (up to 16 Universes / 8192 Channels)
 3. Snap sACN (up to 16 Universes / 8192 Channels)
6. Specify the universes for capturing data
7. Once the option for capturing is selected, press on the start rec button to start the recording. The timer in the right bottom part of the window should start running as soon as data is captured.

The DMX values captured will be shown for the corresponding universe.

Toggle all inputs – Selects all input universes

Save scene - used to save the cue created

Close - Close edit window without saving

Preview – Observe the capture using DMX ports. This will stop any current playbacks

Stop Preview – Stop output of captured data through DMX ports

N.B. During Art-Net recording check if no active Art-Net output is broadcasting to eliminate frames loopback, which leads to the incorrect recording.

Art-Net Triggering

1. Select Dynamic Scene as the cue type
2. Select "ArtNet Trigger" from the Rec. Control option
3. Set the desired universe, channel and value to activate the trigger

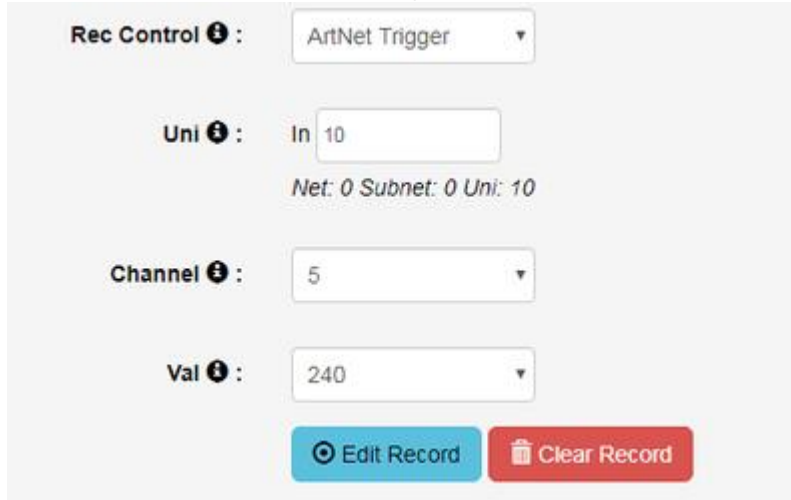

Rec Control ⓘ : ArtNet Trigger ▼

Uni ⓘ : In 10
Net: 0 Subnet: 0 Uni: 10

Channel ⓘ : 5 ▼

Val ⓘ : 240 ▼

Edit Record Clear Record

4. Press edit record button
5. Provide cue name to aid identification
6. Select one of the following options for data capture:
 1. Snap DMX (up to 2 Universes / 1024 Channels)
 2. Snap Art-Net (up to 16 Universes / 8192 Channels)
 3. Snap sACN (up to 16 Universes / 8192 Channels)
7. Specify the universes for capturing data
8. Once the option for capturing is selected, press on the start rec button to start the recording.
9. S-Play will wait then for the trigger to be active before it starts recording
10. The timer in the right bottom part of the window should start running as soon as the Trigger is active, and data is captured

The DMX values captured will be shown for the corresponding universe.

Toggle all inputs – Selects all input universes

Save scene - used to save the cue created

Close - Close edit window without saving

Preview – Observe the capture using DMX ports. This will stop any current playbacks

Stop Preview – Stop output of captured data through DMX ports

N.B. During Art-Net recording check if no active Art-Net output is broadcasting to eliminate frames loopback, which leads to the incorrect recording.

N.B. The Art-Net trigger will be **active, once the value of the channel is equal to or greater than** the value set in the trigger.

Playback

Preview Cue

- Access a Cue
- Click Preview Cue
- Cue is previewed on the selected output ports

When previewing a static cue, stop the preview when done.

Playlists

The playlist page allows the user to add multiple cues (static or dynamic), events and triggers in a sequence to be stored and played back at any given point.

Playlist Page Layout

The screenshot displays the ENTTEC Playlist Page Layout. At the top, the ENTTEC logo is on the left, and navigation links for EN, CN, and Login are on the right. Below the logo, a navigation menu includes Home, Cue Library, Events, Triggers, Playlists (highlighted), Scheduler, Settings, Status, and Backup. The current date and time are shown as Nov 12 2019 16:01:36 PM.

The main content area is divided into several sections:

- A:** A header bar with "All Playlists" and a play/pause icon.
- B:** A "Display" dropdown set to 30 and a "Pages" indicator showing 1 / 0.
- C:** A "Create New Playlist" button and a "Search items..." input field.
- D:** A horizontal menu with four tabs: "Static cue" (blue), "Dynamic cue" (dark blue), "Events" (green), and "Triggers" (orange).
- E:** A "Playlist Attribute" panel with fields for Name (playlist), Priority (100), Loop (Infinity), Group (0), and Start Up Trigger (No Trigger).
- F:** A control bar with a lock icon, a trash icon, and playback controls (stop, play, pause, next). The time display shows 00:00:00 / 00:00:00.
- G:** A timeline view with a grid showing time intervals (00:00, 05:00, 10:00, 15:00) and multiple "Cue Track" entries, each with a 100% volume indicator.
- H:** An "Event" section.
- I:** A "Triggers" section.

At the bottom of the page, there is a footer with the text: © 2019 ENTTEC | [Enttec Web](#) | [Contact us](#)

The page has 8 different section

- a. Created Playlists
- b. Global Playlist Control

Playlist Editor

- c. List of Playlists
- d. Available cues and controls
- e. Playlist attributes
- f. Playlist settings
- g. Playlist timeline and Media tracks

- h. Event track
- i. Trigger track

Created Playlists

This section lists all the playlist created. The section displays basic information like the playlist name and duration and gives the user basic control over a playlist

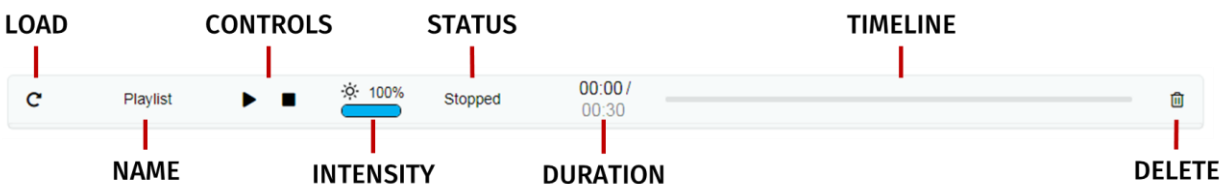

Load: loads the playlist in the timeline and media track for editing

Name: Display the name of the playlist set in the playlist attribute section

Controls - Play/Pause, Stop

Play: Play the selected playlist, also the Playlist is loaded into the timeline and media track section

Pause: Pause the selected playlist. By pausing a playlist, S-Play holds the las DMX value.

Stop: Stops the selected playlist. By stopping a playlist, S-Play stops outputting any data (set DMX value t 0)

Intensity: real-time control of the master intensity of the playlist. By default, it is set to 100% and it can be changed when the playlist is playing.

Status: states the status of the playlist. It can be: *Playing, Paused, Stopped, Waiting for Trigger.*

Duration and timeline: real-time count down of the playlist. Actual time / Duration of the Playlist. Once the playlist is done playing, S-Play stops outputting any data.

Delete: Deletes the playlist and schedules where the playlist is used.

Global Playlist Control

Gives control over all the created playlists. When pressing play on the global control, all the playlists start playing. If there are conflicts in channels, the values are merged on HTP. The playlists with higher priority override the other values played.

List of Playlists

This dropdown menu lists all the created playlist. For editing select a playlist from the list. To create a new Playlist, select "Create New Playlist" from the list. This entry will always be the first entry of the menu.

Available cues and controls

Lists all the media that can be used in the playlist. It is categorized by Static Cues, Dynamic Cues, Events and Triggers.

To use any media, drag and drop the desired cue into any of the media tracks. Please note that triggers and events have dedicated tracks.

Playlist attributes

Name: Set the name of the playlist.

Internal Priority: when playing multiple playlists, for any conflict between channels, the playlist with higher priority will drive the output. If the playlist has the same priority the channels will merge following HTP (Highest takes precedence) method.

Loop: Determine the number of times that the playlist will play until it stops

Group: Group playlists to override the output. Groups with higher hierarchy drive S-Play output.

Start Trigger: List of triggers set in Triggers page, except "On Power Up" which triggers playlist right after Splay power-ups. These triggers are used to start the playlist. To use this feature, just select a Trigger from the dropdown menu; the Playlist will play by either pressing play or activating the trigger.

Playlist Attribute

Name	<input type="text" value="Playlist"/>
Internal Priority	<input type="text" value="100"/>
Loop	<input type="text" value="1"/>
Group	<input type="text" value="0"/>
Start Trigger	<input type="text" value="No Trigger"/>

Playlist Settings

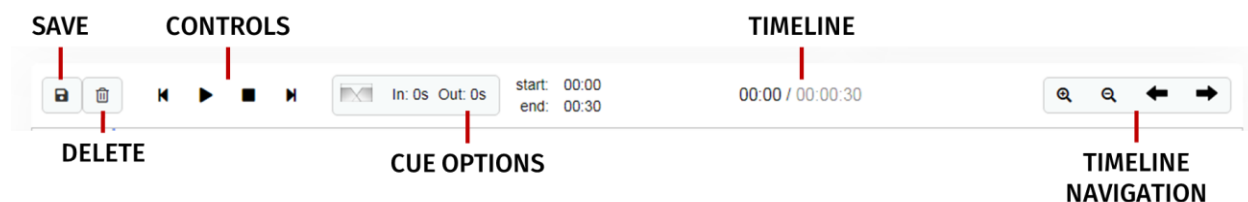

Save: Saves any change on the Playlist. S-Play will ask to save any change before playing a Playlist.

Delete: Deletes the playlist loaded in the Playlist Editor

Control: Gives control to the playlist loaded in the Playlist Editor

Cue Options: Options for any cue added into the cue track. The cue options are also active when a cue in the cue track is selected.

Fade: Set the fade in and fade out time for a cue. It will go from 0 to max intensity in the set period.

Start/Duration: Manually add the start time for the selected cue. On a static cue, you can change the duration by also editing the end time. On a Dynamic cue, the duration is set according to the recording.

Timeline: Shows the current time of the playlist out of the total duration of it.

Timeline navigation: Zoom in and Out using the magnifying glass with the plus and minus symbol. Note that when you zoom in/out, the values in the timeline change and the size of the cue boxes change.

Use the arrows to move on time in the playlist timeline.

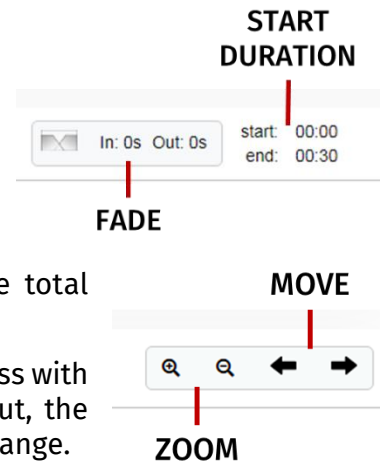

Playlist timeline and Media tracks

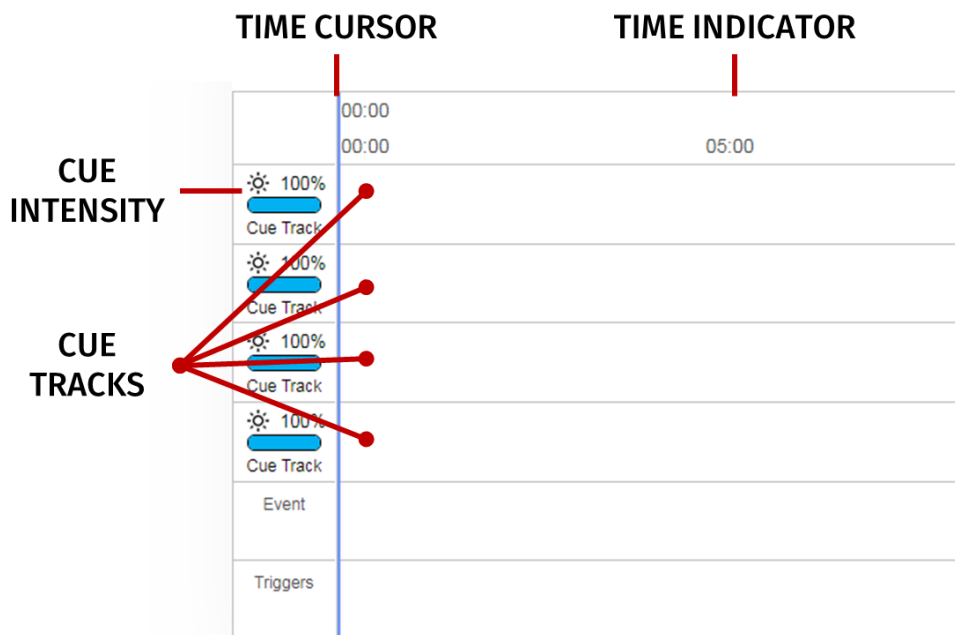

S-Play has 4 different cue tracks where any cue from the playlist media section can be dragged on.

Intensity: Each track has its own intensity and it affects all the media on the same level.

Cue tracks: Drag and drop media to this section. To remove a cue from the tracks, select the cue and click on the red **x** next to the right edge of the box.

When playing multiple media at the same time. i.e. 2 cues on 2 different tracks, S-Play will use HTP (Highest value Takes Priority) merging.

Event and Trigger tracks

These tracks are reserved for events and triggers respectively. The vertical line shows the exact moment playlist will pause to wait for the trigger to be active, or the playlist executes the event. When using triggers, the playlist pauses and holds the last value on the output. To continue, activate the selected trigger or press play again.

Example Playlist

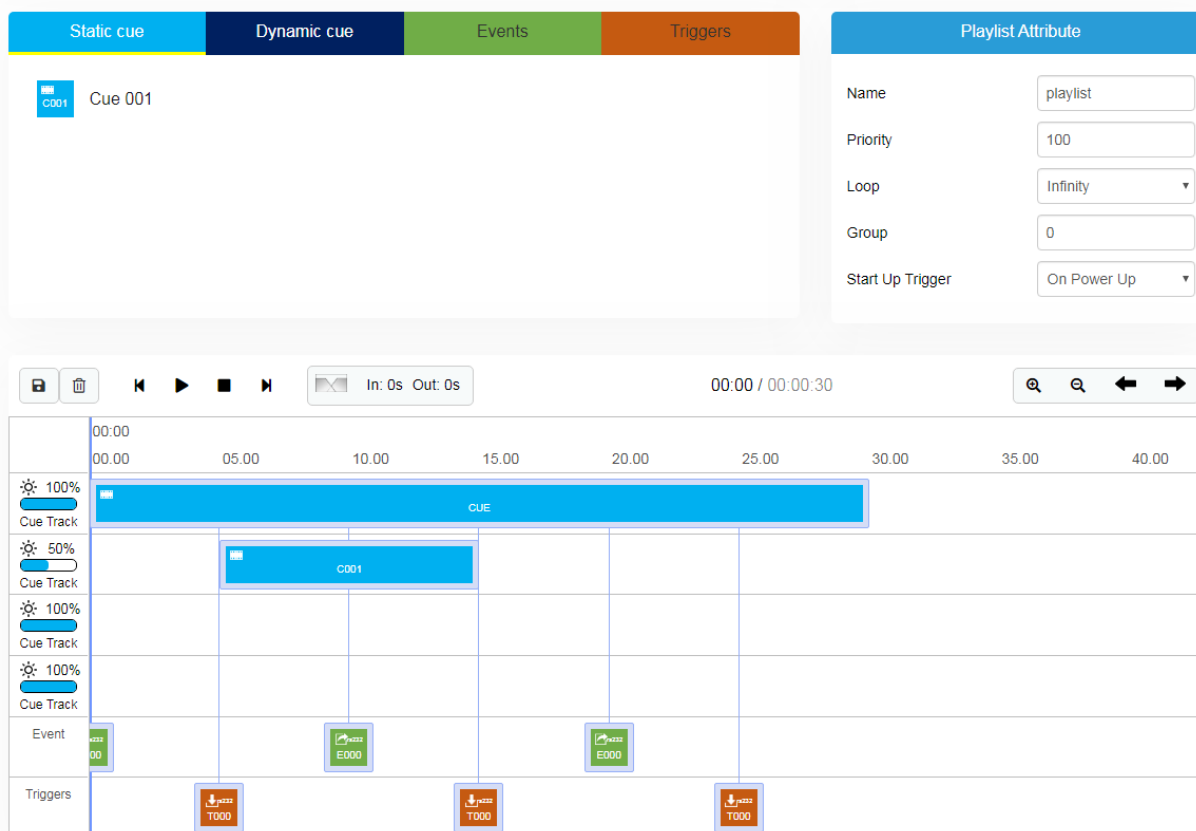

This example is showing a playlist named "playlist" that will start on power up and will loop until manually stopped (Loop: Infinity)

The static cue "CUE" will play while sending an RS232 Event. By second 5 the playlist will pause and wait for the GPIO trigger to be sent an C001 will start playing with 50% intensity. The playlist will then continue sending Events and waiting for triggers. At second 30 it will loop back sending the first RS232 Event out.

Control

Events

Use events to allow integration between S-Play and other devices. S-Play can send commands over multiple protocols and interact with Relays.

RS232

Make sure the receiver has the correct communication setup:

- Baud rate: 9600
- Data: 8bit
- Parity: None
- Stop: 1bit
- Flow Control: none

N.B. Command text is limited to 32 Characters only.

Art-Net

Unicast or broadcast a value over a specified channel and universe over Art-Net

Set the following:

- IP Address (if unicasting)
- Output Universe
- Channel
- Value

DMX

Send a value over a specified channel on the DMX port of your choosing.

Set the following:

- DMX Port
- Channel
- Value

sACN

Unicast or multicast a value over a specified channel and universe over sACN.

Set the following:

- IP Address (if unicasting)
- Output Universe
- Channel
- Value

Control Options

Control Name: sACN Event

Type or Protocol: sACN

When activated, S-Play will send selected DMX value
DMX value is sent over sACN as specified below

On Unicast IP: 10 . 10 . 3 . 153

sACN Uni: 10

Event Channel: 9

Event Value: 250

Save Control Reset Control

Relay

Control the relay action

- NO: Normally Open
- NC: Normally Closed

N.B. On system power-up, the Relays position is set to be normally open.

Control Options

Control Name: Relay Event

Type or Protocol: Relays

When activated in a playlist the Relay will perform the selected action

NO: Normally Open
CM: Common
NC: Normally Closed

Relay Selection: Relay 1

Relay Action: NC

Save Control Reset Control

Triggers

Use triggers to take control of the timeline of the playlist. When using a trigger, the timeline will pause until the selected trigger is active.

Triggers can be used to start a playlist or at any point within the timeline.

When a playlist is waiting for a trigger, it will play by either activating the trigger or by pressing play. This way there is full control of the playback even when the triggers are not available.

OSC

Change OSC Port in settings page: “OSC PORT”

S-Play can interact with OSC in multiple ways. Triggers can be created to start and resume playlists, but there is also a close integration with the OSC API that enables control of:

- Master intensity
- Play, pause and stop all playlists
- Play, pause and stop individual playlists
- Playlist intensity

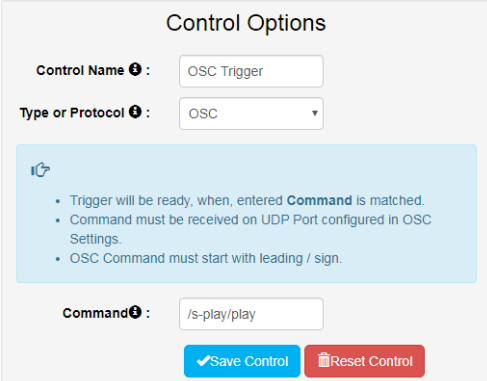

Control Options

Control Name ⓘ :

Type or Protocol ⓘ :

ⓘ

- Trigger will be ready, when entered **Command** is matched.
- Command must be received on UDP Port configured in OSC Settings.
- OSC Command must start with leading / sign.

Command ⓘ :

Export Playlists in the OSC section in the settings page will download a .csv that contains the Playlist ID and Playlist name.

Visit www.enttec.com to download the OSC API, or follow this [link](#).

RS232

RS232 Communication settings:

- Baud Rate: 9600
- Data: 8bits
- Parity: none
- Stop: 1bit
- Flow Control: None

N.B. Command text is limited to 32 Characters only.

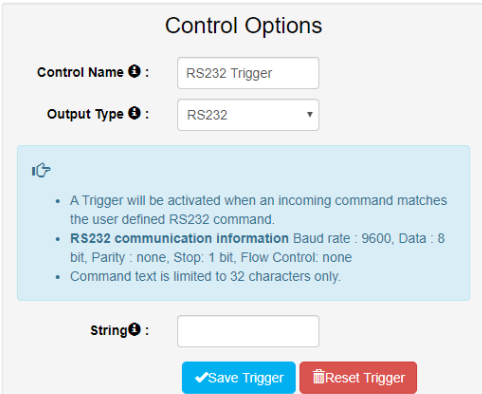

Control Options

Control Name ⓘ :

Output Type ⓘ :

ⓘ

- A Trigger will be activated when an incoming command matches the user defined RS232 command.
- **RS232 communication information** Baud rate : 9600, Data : 8 bit, Parity : none, Stop : 1 bit, Flow Control: none
- Command text is limited to 32 characters only.

String ⓘ :

DMX

DMX trigger will be active when the trigger value is equal and greater than the selected trigger value.

Set the following:

- DMX Port
- Channel
- Value

N.B. If DMX is selected as output protocol in the setting page, the DMX triggers will be disabled in the playlist.

Control Options

Control Name

Type or Protocol

When used in a playlist, S-Play will wait to receive the selected DMX value over the specified Port and Channel

DMX Port

Trigger Channel

Trigger Value

Digital Input

S-Play has 4 Digital input ports to activate triggers. **The triggers will be activated when the digital input is in low position (normally closed).** If the input remains on low position while the timeline goes over the trigger, the playlist won't pause.

Use GPIO triggers with sensors, pressure pads, wall switches, etc.

Control Options

Control Name

Type or Protocol

Idle position for digital input is high

Trigger is executed when digital input position is low

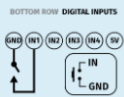

Ports

Art-Net

Art-Net trigger will be active when the trigger value is equal and greater than the selected trigger value.

Art-Net trigger can be unicasted or broadcasted to S-Play.

It is recommended not to use the same universe used in playback.

Set the following:

- Input Universe
- Channel
- Value

Control Options

Control Name

Type or Protocol

When used in a playlist, S-Play will wait to receive the selected DMX value over the specified Art-Net Universe and Channel

Universe Net: 0 Subnet: 0 Uni: 0

Trigger Channel

Trigger Value

SACN

sACN trigger will be active when the trigger value is equal and greater than the selected trigger value.

sACN trigger can be unicasted or multicasted to S-Play.

It is recommended not to use the same universe used in playback.

Set the following:

- Input Universe
- Channel
- Value

Schedule

To set up a scheduler you need to create a playlist first. The scheduler will play the playlist at a set time until the end condition is met. i.e. *PlaylistA* can be played every day on sunset from the 1st of February until the last Friday of October.

The playlists played by the scheduler will play next if there is a playlist playing when the initial condition is met. In the previous example, if S-Play is playing *PlaylistB* right before sunset, S-Play will wait for it to finish to play *PlaylistA* set in the scheduler.

Give attention to the setup of Date & Time and Location settings for the correct work of Schedulers.

ENTTEC

The page has 7 different sections:

a. Created Schedules

Scheduler Editor

b. List of Schedules

c. Schedule name

d. Selected playlist

e. Start condition

f. End condition

g. Frequency type

Created Schedules

PLAY PAUSE	STATUS	SCHEDULER NAME	PLAYLIST NAME	PLAYLIST LOOP	SCHEDULER FREQUENCY	START TIME	START DATE	END CONDITION	DELETE
C LOAD	● Activated	ONCE A YEAR	Playlist	Infinity	Frequency: Hourly	Time: 20:30	Start: 2019-11-18	End: 2019-11-18	[trash icon] DELETE

The created schedulers list gives information at a glance of the parameters set on each scheduler.

Pause/Play: Gives control of the scheduler. If a scheduler is paused, the status light will become yellow.

Load: Load scheduler into the Scheduler Editor to update or change any parameter

Status: Displays the status of the scheduler

- Green: Active Scheduler. An active scheduler still has instances to play
- Red: Expired Scheduler. An expired scheduler does not have any instances left to play.
- Yellow: Paused Scheduler. The scheduler will not play until it's active and the end condition is not met.

Scheduler name: Name set in the scheduler editor

Playlist name: Playlist selected in the scheduler editor

Playlist Loop: loop set in the scheduler editor, by default this is the same value configured in the playlist attributes

Scheduler frequency: frequency set in the scheduler editor

Start time: Time set in the scheduler editor

Start date: Start date set in the scheduler editor

End condition: end condition set in the scheduler editor

Delete: Delete selected scheduler

List of Schedules

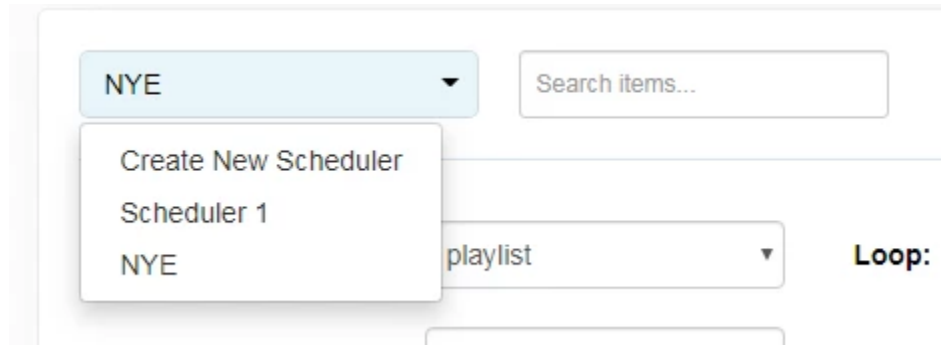

Lists all the schedules saved and shown in the created scheduler section. When an option is selected, its parameters are loaded into the scheduler editor.

To create a new scheduler, select "Create New Scheduler" option.

Schedule name

Name to aid Schedule identification.

Selected playlist

List of available Playlist to be scheduled.

Start condition

Set a schedule to start at a specific time, at sunrise or sunset. The sun phase is calculated based on the location set in the settings page. It takes into consideration:

- GMT Offset
- Latitude
- Longitude

To set the start of the scheduler to a specific time do the following:

- Select "Time" from the dropdown menu

- Click the first two digits on the second dropdown menu and set the hour using the dial. Note that the inner circle show hours past noon (>12) and the outer circle show hours before noon (1AM to 12).

The screenshot shows a scheduler configuration interface. At the top, there are fields for 'Start' (2019-11-18), 'Time' (20:30), 'End' (2019-11-18), 'After' (1), and 'Repetitions'. Below these, there is a 'Frequency Type' dropdown menu with options: Secondly, 1.Minutely, Hourly, Daily, Weekly, 1.Monthly, Yearly, and Astronomical. To the right of the 'Time' dropdown is a circular dial for selecting the hour, with an inner circle for hours past noon (13-24) and an outer circle for hours before noon (1-12). The dial is currently set to 20. Below the hour dial is another circular dial for selecting the minutes, with numbers from 00 to 55 in increments of 5. This dial is currently set to 30.

- To set the minutes, click on the last two digits and use the dial to select the desired time.

End condition

The scheduler will be expired once the end condition is met. It can be on a specific date or after a desired amount of repetitions.

Frequency type

Set the frequency when the playlist set will play.

The screenshot shows the 'Frequency Type' selection interface. On the left, there is a list of radio buttons for different frequency types: Per Second (selected), Per Minute, Hourly, Daily, Weekly, Monthly, Yearly, and Astronomical. To the right, there is a text input field that says 'Every 1 Second(s)'. Below this, there are two buttons: 'Save Scheduler' (green) and 'Delete' (red).

Per Second

Start the selected playlist after the specified seconds.

Per Minute

Start the selected playlist after the specified minutes.

Hourly

Start the selected playlist after the specified hours.

Daily

Start the selected playlist either every day or every number of days specified.

Frequency Type:

- Per Second
- Per Minute
- Hourly
- Daily
- Weekly
- Monthly
- Yearly
- Astronomical

Every Day

Every **days**

Save Scheduler Delete

Weekly

The selected playlist will play on the selected days every week or as specified in the text box. In the example, the playlist will play every week on Wednesdays and Tuesdays.

Frequency Type:

- Per Second
- Per Minute
- Hourly
- Daily
- Weekly
- Monthly
- Yearly
- Astronomical

<input type="checkbox"/> Monday	<input type="checkbox"/> Tuesday
<input type="checkbox"/> Wednesday	<input type="checkbox"/> Thursday
<input type="checkbox"/> Friday	<input type="checkbox"/> Saturday
<input type="checkbox"/> Sunday	

Monthly

The selected playlist will play a specific day of every month as specified. In the example above, the playlist will play the 1st Day of every month.

- Frequency Type:**
- Per Second
 - Per Minute
 - Hourly
 - Daily
 - Weekly
 - Monthly
 - Yearly
 - Astronomical

Day 1 of every 1st month

The 1st Monday of every 1st month

Yearly

The selected playlist will play a specific day of the year. In the example above, the playlist will play every year on the 1st of January.

- Frequency Type:**
- Per Second
 - Per Minute
 - Hourly
 - Daily
 - Weekly
 - Monthly
 - Yearly
 - Astronomical

The January 1

On the 1st Monday of January

Astronomical

The selected playlist will play depending on the phase of the moon. In the example above, the playlist will play every new moon.

- Frequency Type:**
- Per Second
 - Per Minute
 - Hourly
 - Daily
 - Weekly
 - Monthly
 - Yearly
 - Astronomical

New Moon

First Quarter

Full Moon

Third Quarter

Setup

Changing the Network Settings

Changing the Network Settings Using LCD Interface

1. Use the up or down navigation buttons located next to the screen to move to the Settings tab

2. Use the down button to navigate to the Network settings page

The Network page can be used for the following:

- Enable or disable DHCP
- Set static IP value
- Set netmask
- Set Gateway

Use the arrows and enter keys to get the desired network settings

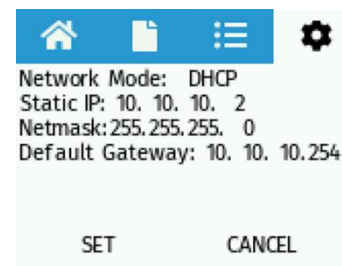

Setting IP Example

1. Toggle between DHC and Static by pressing enter to change options and the up-down arrow to change between options
2. Press Enter button to move to IP address
3. Use the arrows to assign a number for each byte in IP; press on the right-left arrow to jump in tens, use the up-down arrow to move by one number
4. Once desired IP is set, press enter button to move to Netmask settings
5. Repeat step 3 to set the desired netmask
6. Once desired Netmask has been set, press enter to assign Gateway settings
7. Repeat step 3 to set the desired Gateway – (this can be set to any IP on the same SubNet as your S-play if a gateway is not required)
8. Press Enter to move out of network settings;
9. Use the arrows to navigate to **Ok** button and press Enter
10. All network settings assigned will get saved once **Ok** button is selected

Change IP Using Web Interface

Change the Network settings between DHCP and Static IP, Netmask and Gateway.

Network Interface ⓘ

DHCP: Off

IP Address: 10 . 10 . 3 . 100

Net Mask: 255 . 255 . 255 . 0

Gateway: 10 . 10 . 3 . 254

[Update Network Settings](#)

S-Play Output

Change outputs independently between ArtNet, sACN and DMX.

S-PLAY Outputs ⓘ Default Configurations ▾

Universe 1:	Art-Net 1 ▾	Universe 2:	Art-Net 2 ▾	Universe 3:	Art-Net 3 ▾	Universe 4:	Art-Net 4 ▾
Universe 5:	Art-Net 5 ▾	Universe 6:	Art-Net 6 ▾	Universe 7:	Art-Net 7 ▾	Universe 8:	Art-Net 8 ▾
Universe 9:	Art-Net 9 ▾	Universe 10:	Art-Net 10 ▾	Universe 11:	Art-Net 11 ▾	Universe 12:	Art-Net 12 ▾
Universe 13:	Art-Net 13 ▾	Universe 14:	Art-Net 14 ▾	Universe 15:	Art-Net 15 ▾	Universe 16:	Art-Net 16 ▾

⚙ Update Outputs

Use the Default configurations option in the top part of the section to quick select Art-Net, sACN, DMX and None.

Art-Net output configuration

- Configure output refresh rate for all Art-Net output stream
- Set output Art-Net each of the 16 universes
 - Universe
 - Unicast IP address
 - Broadcast
- Save after any change by pressing "Update Art-Net"

Art-Net ⓘ

Refresh Rate: 44 ▾ fps

Output:

ArtNet 1: 0 Net:0 Subnet:0 Universe:0

On Unicast IP: 192 . 168 . 0 . 1

⚙ Update Art-Net

SUCCESS. Art-Net updated successfully. ✕

N.B. max refresh rate = 60FPS

sACN output configuration

- Configure output refresh rate for all sACN output stream
- Set output sACN each of the 16 universes
 - Universe
 - Unicast IP address
 - multicast
- Save after any change by pressing "Update sACN"
- Generate sACN ID
- Set S-Play sACN priority

sACN ⓘ

Refresh Rate: 60 fps

sACN 1 : Output: 40

Off Multicast IP: 239 . 255 . 0 . 1

sACN ID: ffa2-b0fa-80b4-4886-

Priority: 200

N.B. max refresh rate=60FPS

DMX output configuration

- Configure output refresh rate for all DMX output streams
- Configure a specific universe to a DMX port

DMX Output ⓘ

Refresh Rate: 44 fps

DMX 1: Port 1 DMX 2: Port 2

Change Date/Time and Location

Set time, date and location. This information is critical when setting schedules.

Date & Time ⓘ

Set Date: Off

Date: 24 October 2019

Time: 12 : 27

Time Zone: Australia/Melbourne

NTP Server: 0.au.pool.ntp.org Daily

Location ⓘ

GMT offset: + Hrs: 11 Min: 04

Latitude: 55 ° 25 ' North South

Longitude: 160 ° 11 ' East West

Calculated: Sunrise: 07:34 Sunset: 17:21

When the set date is off. The NTP server will update the system time information. An internet connection is required to configure the NTP.

Factory Reset

When performing a factory reset the S-Play:

- IP address will go back to DHCP
- Delete all cues, playlists and schedulers
- Output will be set to DMX1 and DMX2
- Art-Net output will be set to broadcast
- sACN output will be set to multicast

Factory reset is possible from the web interface and from the menu displayed in the LCD screen.

LCD

- Navigate to settings
- Locate Reset to Defaults
- Select “RESET”

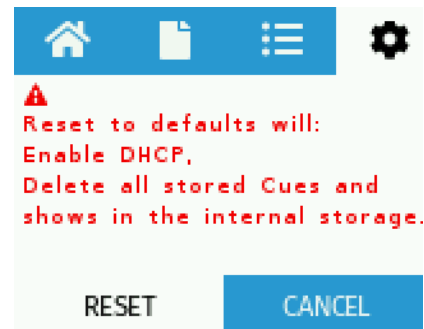

Via web interface

Go to settings page, scroll down to the end of the page and click “Reset to factory Defaults”

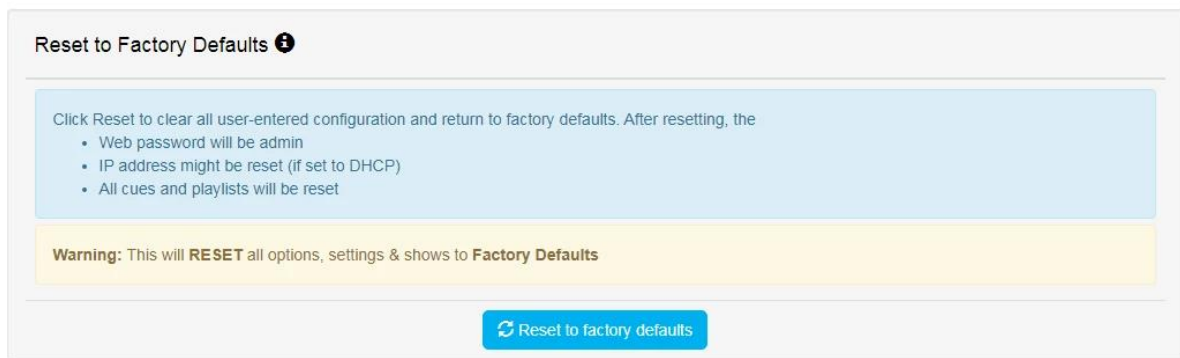

Backup

S-Play produces a package that includes:

- ✓ Cues
- ✓ Playlist
- ✓ Schedules
- ✓ Settings

The backup can be done via LCD and web interface.

Go to Backup page, click “Backup”. The process produces a *.bak* package that can be downloaded and saved to any location in your computer.

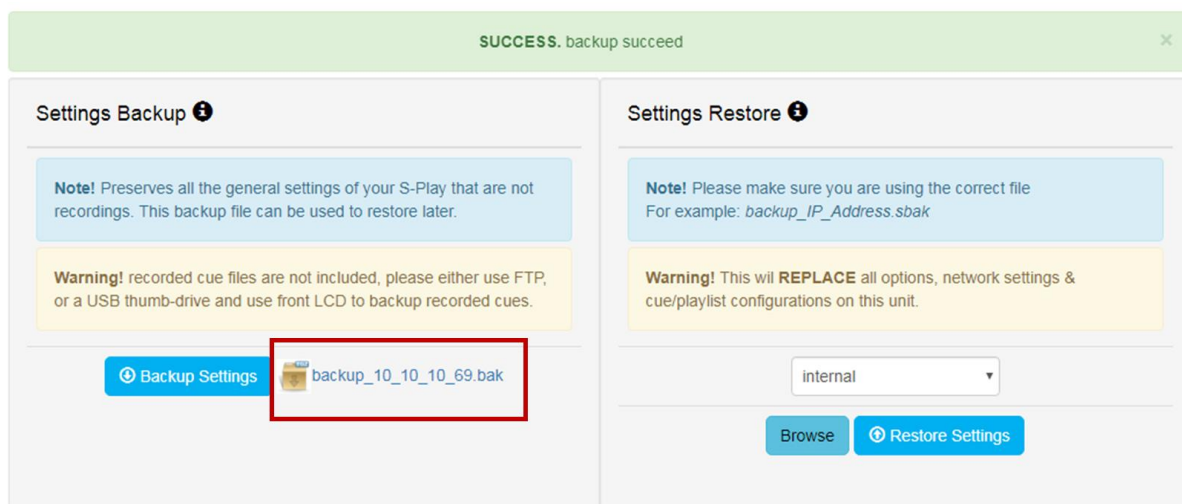

Restore

Use the created *.bak* file to restore cues, playlists, schedules and output settings.

Go to the *Backup* menu in the web interface

- Select the desired memory (internal or external)
- Click browse and look for the *.bak* file
- Insert and click on restore

Once the restore is complete, a

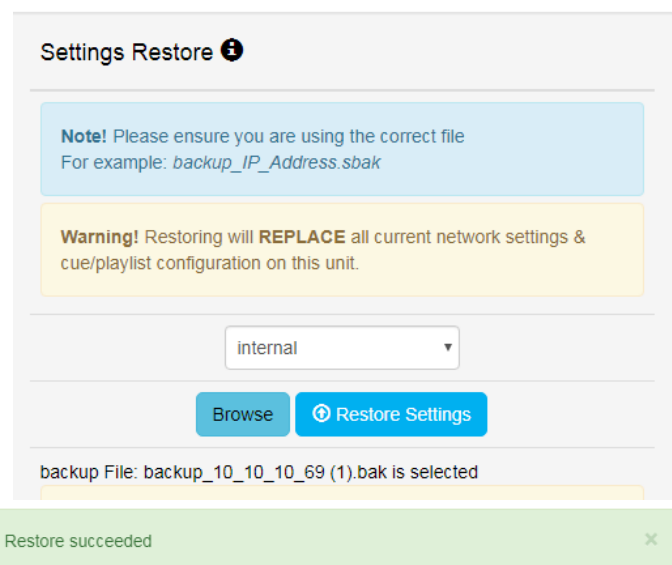

confirmation message will appear on the top of the page.

Storage

Static Cue

Snapshots are comprised of a single DMX frame. The maximum file size of a frame of one universe with associated metadata is 4.5Kb. To calculate the file size of a Static Cue.

To calculate the theoretical file size of a static cue, multiply 4.5Kb by the quantity of universes you intend to capture as part of the static cue. This calculation will give a file size in Kb.

$$((4.5\text{Kb}) * (\text{Quantity of Universes to be captured})) = \text{Cue Size (Kb)}$$

Dynamic Cue

A dynamic cue can be thought of as a stream of Static Cues. To calculate the theoretical file size of a Dynamic Cue the size of a single 1 universe DMX frame (4.5Kb) should be multiplied by the quantity of universes being captured, the quantity of frames being recorded per second and duration of recording (in seconds).

$$((4.5\text{Kb}) * (\text{Quantity of Universes to be captured}) * (\text{Quantity of Frames per Second [produced by the DMX source]}) * (\text{Intended Recording Length [seconds]})) = \text{Recording Size (Kb)}$$

Triggers & Events

Triggers and Events each have a maximum file size of 4.5Kb. To calculate the theoretical storage size all Triggers and Events your configuration will occupy, multiply the total quantity of Triggers and Events you will use by 4.5Kb.

$$((4.5\text{Kb}) * (\text{Quantity of Triggers and Events})) = \text{Total Trigger and Event Size (Kb)}$$

Select Storage

S-Play contains internal memory. However, if the storage is getting full, the user can switch memory to an external Class 10 SD Memory card designed for high load video recording is used. (i.e. Samsung Pro Endurance series).

S-Play can only operate from a single memory source so make sure to move all the files from the internal memory to the external SD card. To do so, please refer to the next section in the user manual “Export Playback Data”

Select Storage ⓘ

Note! Change storage which stores all cues, playlists, schedules and settings.

sd ▼

✓ Select Storage

When a SD card is inserted into the S-Play it will be wiped and re-formatted to support the Linux EXT4 file format before shows are saved onto it. Ensure all files are removed from your SD card before inserting it into the S-Play.

Export Playback Data

Export playback data moves:

- Cues
- Playlists
- Schedules

from the internal memory to an external SD card inserted in the front slot of the unit or vice versa.

When moving files across make sure the desired storage is selected in “Select Storage” section on the web interface.

The files are copied from one location to another. Which means that they are not deleted from the original location.

The status of both memory devices can be tracked down in the “Status” page.

Export Playback Data ⓘ

Note! Export data from one storage to another replacing previous playback data on target storage

From: sd ▼

To: internal ▼

✓ Export Storage

Locking the unit and user management

S-Play includes a locking system to prevent changing settings, deleting playlists, cues and schedulers from unauthorized users.

How to use the Lock feature

Out of the box, S-Play is unlocked which means when connected to a network any computer within the network can change settings, create cues, create playlists, trigger playlists, etc.

If the lock on the top right corner of the screen is open, as shown below, the unit is unlocked and accessible within the network.

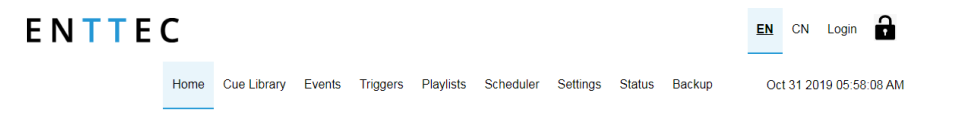

To lock the unit, simply click on the Lock and the unit will automatically disable all the tabs but home.

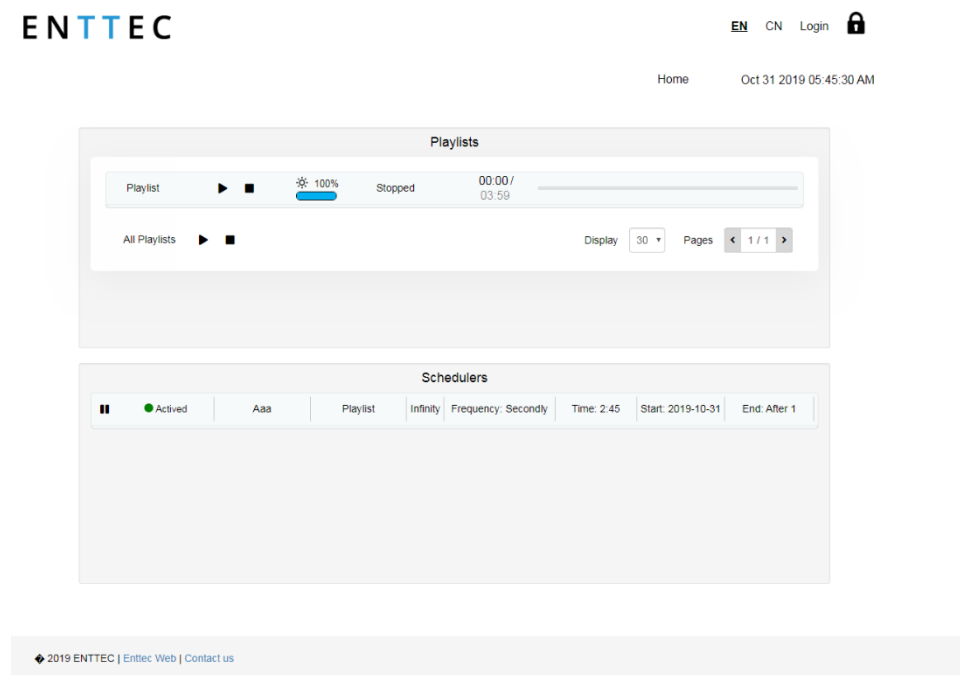

When the S-Play is locked, the users can:

- Play and Stop any playlist
- Play and Stop all playlists
- Pause and Resume Schedulers
- Navigate the LCD to preview cues, activate playlists and **display** settings

To enable functionality the user needs to log in.

When a user is logged in, the unit can remain locked for the rest of the users accessing from other locations/browsers. Within the network. However, the unit will force only one browser open at the same time when accessing "Home", "Cue Library" and/or "Playlist Page". This is to avoid having conflicting commands that can jeopardize the light installation.

To unlock the unit, just click on the lock icon on the top right corner.

User information and passwords

USERS	DEFAULT PASSWORD
User	123456
Admin	enttec+6 last digits of MAC i.e. MAC: 00:50:C2:07:E6:78 Password: enttec07E678

Status

Network Information ⓘ

IP Address:	10.10.10.118
Subnet Mask:	255.255.255.0
Broadcast Address:	10.10.10.255
Serial No. / Mac Address:	00:50:C2:07:F0:73

Output Information ⓘ

	Universe 1	Universe 2	Universe 3	Universe 4	Universe 5	Universe 6	Universe 7	Universe 8	Universe 9	Universe 10	U
Protocol	ArtNet	ArtNet	ArtNet	ArtNet	ArtNet	ArtNet	ArtNet	ArtNet	ArtNet	ArtNet	A
Universe	0	1	2	3	4	5	6	7	8	9	1
IP Address	192.168.0.1	192.168.0.1	192.168.0.1	192.168.0.1	192.168.0.1	192.168.0.1	192.168.0.1	192.168.0.1	192.168.0.1	192.168.0.1	1

System Information ⓘ

System Status:	✔ STARTED	STOP ENGINE REBOOT
Activity:	No Playlist is Playing	
CPU Status:	Load: 16.8 % Temp: 34.9 °C	
Disk Space:	<div style="display: flex; justify-content: space-between; align-items: center;"> <div style="width: 60%;"> <div style="border: 1px solid #ccc; padding: 2px; margin-bottom: 2px;">5.38 % used</div> <div style="border: 1px solid #ccc; padding: 2px; margin-bottom: 2px;">SD (Internal) 7.39 GB free out of 7.81 GB</div> <div style="border: 1px solid #ccc; padding: 2px;">5.35 % used</div> </div> <div style="width: 35%; text-align: right;"> <div style="border: 1px solid #ccc; padding: 2px; margin-bottom: 2px;">sd mounted on Wed 23 Oct 12:25:18 AEDT 2019</div> <div style="border: 1px solid #ccc; padding: 2px;">13.76 GB free out of 14.53 GB</div> </div> </div>	
System Name:	✎ S-PLAY	
System Uptime:	1 day, 16 minutes	
Hardware ID:	165166cb0a818b9b	

Software Information ⓘ

Software version:	19092018-92 (updated: 19/09/2018)
DMX driver version:	version: 1.41

© 2019 ENTTEC | Enttec Web | Contact us

The Status page displays the following information:

Network Information

- IP Address
- Subnet mask
- Broadcast address
- MAC Address
- Engine Address

Output Information

- Protocol
- Universe
- Output IP Address, if applicable

System Information

- Status
- Activity
- CPU Status
- Disk Space (internal and external)
- System uptime
- Hardware ID

Software Information

- Software Information
- DMX Driver Version

Network Discovery

Built-In IP Address Discovery

1. Ensure your S-Play is hooked up physically by an ethernet cable and connected to a physical network (or router).
2. Power up the device
3. Monitor the LCD menu. The LCD will show IP address when booting up and will display the IP address in the Home page
4. Using a browser on a device within the same network range, type in that IP address in URL window, and that will load the S-Play web page. All configuration can be done using the web page.

Find Device IP Address from NMU

ENTTEC provides a free app (available for Windows and Mac) called NMU (Node Management Utility) that find the S-Play and display its IP address.

Note: S-Play is only supported by NMU v1.93 and above.

Please follow these steps:

1. Download NMU from www.enttec.com
2. S-Play should be connected physically by an ethernet cable to the same physical network (or router) as the computer on which you will run NMU
3. Open NMU. If prompted with multiple network interfaces, select the correct one to which S-Play is connected to
4. Press the Discovery button and wait until NMU finds all supported ENTTEC devices
5. Once found, select S-Play and use the IP address to access the web interface

Note: When S-Play is in static IP, **the default gateway MUST be the same** between the unit and the router for NMU to discover the S-Play.

Specifications

Item	Value
Input Voltage	12 V DC to 24 V DC
PoE	IEEE 802.3af
Supported Protocols	Art-Net 1/2/3, sACN, DMX
Supported Universes	16U Art-Net and sACN 2U DMX
Operating Temperature	-10 to 50°C
Connectors	2X DMX 5Pin 1X RJ45 1X DB9 Male (RS232) 1x DC Jack 1x USB Host 1x Micro SD Card Slot 4x Dry Inputs 2x Relay Outputs
IP Rating	IP 20
Cooling Method	Convection
Shipped Weight	1.25 Kg / 2.76 lb
Packaging Dimensions	272 X 204 X 102mm

Due to continuous improvements and innovations of all ENTTEC products, specifications and features are subject to change without notice.

Tips and Tricks

Network Recommendations

ENTTEC recommends the S-PLAY is configured with a static IP and DHCP turned off. – This will ensure the unit continues to receive commands from devices unicasting to it. – If DHCP is used, there is a chance the S-PLAY can change IP address following its DHCP lease expiring.

With all devices on static IP addresses in the same range ensures more predictable management of devices within the installation.

It is strongly advised that a 'show network' shouldn't be directly connected the internet or made to be part of a VPN without a sufficient firewall in place.

A common method to manage show and other connected devices in the network remotely is to use a remote computer with two network adaptors, one to remote into the PC over the internet, the second without an internet connection purely for show critical data.

Unable to connect to S-Play IP address, what now?

1. Please connect S-Play directly using a cat5 cable to your computer. (remove switch or router)
2. Give your computer a Static IP address 10.0.0.1
3. Change computer Netmask to 255.0.0.0
4. Set default gateway to 10.0.0.254
5. Connect S-Play now
6. Try and connect to the IP address displayed on the screen now.
7. This will be the static IP address, which can be changed using the section above, as required

My recorded sequence contains parts of a different recording inside it

When recording new sequences, it is important you know where all sources of DMX data originate from.

When recording into the S-PLAYS Cue Library, ensure your S-Play is not playing back any playlists with their output universes set to Broadcast, Multicast or with the Unicast Destination IP matching the S-PLAY. If either of these this is the case your S-PLAY will receive data that's being played back.

Using Motion sensors with S-Play

Diagram

CONNECTION

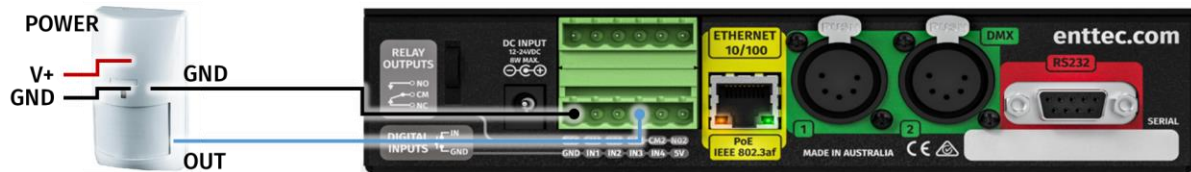

WEB SET UP

EN CN Login

Home Cue Library Events **Triggers** Playlists Scheduler Settings Status Backup Nov 18 2019 16:23:38 PM

Show 20 Controls Search Controls ...

ID	Name	Protocol
1	Trigger 000	RS232
2	Trigger 001	Digital Input
3	Trigger 002	Digital Input
4	Trigger 003	N/A
5	Trigger 004	N/A
6	Trigger 005	N/A
7	Trigger 006	N/A
8	Trigger 007	N/A
9	Trigger 008	N/A
10	Trigger 009	N/A

Control Options

Control Name:

Type or Protocol:

Ports:

• Idle position for digital input is high
• Trigger is executed when digital input position is low

BOTTOM ROW DIGITAL INPUTS

Steps

1. Connect out dry input from sensor to Port3 (or any other port on the bottom connector) in the GPIO trigger connector in S-Play
2. Connect ground from sensor to GND connector in the GPIO trigger connector in S-Play
3. Go to web interface
 - Go to “Triggers”
 - Click on an empty entry
 - Change name on control name
 - Select Digital Input from “Type”
 - Change to Port 3 in “Ports” (or to the corresponding port the OUT cable was connected to)
 - Click on save control

4. Trigger is saved in the unit and it is ready to be used in a Playlist or as a trigger to start a playlist

The screenshot displays the ENTTEC S-Play software interface. At the top, there are four tabs: 'Static cue' (blue), 'Dynamic cue' (dark blue), 'Events' (green), and 'Triggers' (orange). Below these tabs, a list of triggers is shown: 'Trigger 000', 'Trigger 001', 'Trigger 002', and 'GPIO 3'. The 'GPIO 3' trigger is highlighted with a red box. To the right, the 'Playlist Attribute' panel is visible, showing fields for 'Name' (playlist), 'Priority' (100), 'Loop' (Infinity), and 'Group' (0). A 'Start Up Trigger' dropdown menu is open, showing options: 'No Trigger', 'On Power Up', 'Trigger 000', 'Trigger 001', 'Trigger 002', and 'GPIO 3'. The 'GPIO 3' option is selected and highlighted with a blue background. Below the trigger list, there is a playback control bar with 'start: 00:00' and 'end: 00:16'. The main area shows a cue track with a cue labeled 'C002' at 00:00. The 'Triggers' section at the bottom left shows a 'GPIO 3' trigger icon with a red 'x' next to it, also highlighted with a red box.

enttec.com

MELBOURNE AUS / LONDON UK / RALEIGH-DURHAM USA