



# YEELM™

ENTTEC LED MAPPER



**Effortless LED Mapping**



## Contents

Key Features.....	3
Computer Requirements.....	3
Licenses.....	5
Software Updates.....	5
Definitions.....	6
Getting Started With LED Strips .....	7
Quick Overview .....	8
ELM Tour .....	9
Home Screen.....	9
New Stage Dialog.....	10
Stages.....	11
Status Indicator.....	12
Stage Syncing.....	12
Stage Merging and Layering .....	13
Edit Zone.....	14
Strips Tab.....	16
Stage Tab.....	25
Testing Tab.....	27
Stages Manager .....	29
Media Library .....	30
Schedules.....	33
Live Mode.....	35
Settings.....	37
Project .....	37
Art-Net.....	38
sACN .....	38
KiNet.....	39
Audio .....	39
Time .....	40
Colors .....	40
License.....	40
Remote Control .....	41
Troubleshooting .....	48
EULA.....	51



## Key Features

ELM is all about displaying your video content on LED fixtures of any shapes, in the most convenient way.

- ✓ Vector-based editor
- ✓ 2048 DMX universes
- ✓ Art-Net, sACN, KiNet
- ✓ Scheduled playlists
- ✓ Remote control via DMX, OSC and HTTP
- ✓ CITP/MSEX for consoles and visualizers
- ✓ HD video + audio playback
- ✓ Spout + NDI integrations for live video inputs
- ✓ Stream LED previews to visualizers via NDI
- ✓ DVI outputs for projectors, TVs and Martin P3 system
- ✓ Over 100 high quality animations included
- ✓ Audio-reactive effects
- ✓ RGB, RGBW, RGBA, RGBAW
- ✓ Multiple whites support and WWA
- ✓ 16-bit color support
- ✓ Extreme robustness for permanent installations



## Computer Requirements

ELM is compatible with Windows 7 and up, including Windows 8 and 10. 32-bit and 64-bit versions are provided to suit your OS.

The .Net 4.7 framework is required and you'll be prompted to install it if needed.

### Minimum

- Windows 7+, dual core 2 GHz CPU, 2 GB RAM
- NVIDIA GeForce 600 series or Intel HD Graphics 5500, released after 2013 with OpenGL 3.3 support

### Recommended

- Windows 8 or 10, quad core 3.5 GHz CPU, 8 GB RAM
- NVIDIA GeForce 900 series or NVIDIA 10 series or better
- SSD hard drive



The computer requirements depend on your media type. For example, playing multiple HD videos requires a good computer. A rule of thumb is you can play one full HD video @ 30fps for each 2 GHz CPU core. So if you have an Intel i7 4 GHz (4 cores), you should be able to play 8 full HD videos. Increasing the playback speed to 2x means the fps also increases two times and the number of videos you can play simultaneously is roughly divided by two.

The next table shows the approximate number of videos you can play simultaneously at 30 fps depending on your CPU.

<b>CPU Speed x Cores</b>	<b>Full HD Videos</b>	<b>HD Videos</b>	<b>640x360 Videos</b>
<b>2 GHz x 2</b>	2	4	10
<b>3 GHz x 2</b>	3	6	15
<b>4 GHz x 2</b>	4	9	20
<b>2 GHz x 4</b>	4	9	20
<b>3 GHz x 4</b>	6	13	30
<b>4 GHz x 4</b>	8	18	> 40
<b>3 GHz x 8</b>	10	22	> 40

For live video performances, when you want to change the playback speed and go up to 10x, the recommended video resolution is 640x360.

To use the built-in effects, particularly the eye candy effects, the video card will be doing the hard work. If you're using a laptop, make sure it can sustain a continuous use of the effects without overheating. Usually, an integrated video card can render two eye candy effects. For more effects, you need to have a discrete video card.

About the DMX output, a 1 Gigabit network should be able to handle 2048 universes @ 44fps. For more universes, a supplementary network card and a second Ethernet network are recommended.



## Licenses

The ELM's licensing system has been built with reliability and simplicity in mind. Basically, once a computer has been activated, it will be able to run ELM until it dies. No internet connection required, so you can be completely off the grid without worrying about the license.

Each license is registered to one individual or company and covers the activation of the software on a certain number of computers, so long as ELM is running on one computer at a time. For example, you can activate a show and a backup computers but only one computer can run ELM at a time.

The license is a simple file that you import once. No hardware dongles are needed, eliminating a whole range of tricky problems: broken dongle, lost dongle, dongle suddenly not detected in the middle of the show, etc.

The license is linked to your computer's CPU and motherboard. You can upgrade any other components and reinstall the OS without invalidating your license.

A license isn't transferrable, meaning once your computer stops working, you can only activate ELM on another computer if you still have activations left. Use this online form to activate a computer: <https://www.enttec.com/my-account/license-registration/>.

To get more DMX universes, you can activate multiple licenses on the same computer. The DMX universes of all licenses will be added.

## Software Updates

You always have access to the latest and greatest version, free of charge.

To get the updates, go in the Settings/About menu and press the check for updates button. Alternatively, you can go on the Enttec's website and download the latest version.

<https://www.enttec.com/products/controls/pixel-control-controls/software-pixel-mapping/>



## Definitions

**Art-Net:** Protocol to transmit DMX over a standard Ethernet network. Designed by and Copyright Artistic Licence Holdings Ltd.

**CITP/MSEX:** Controller Interface Transport Protocol/Media Server Extension.

**DMX:** The most common protocol to control lighting fixtures. The full name is DMX512, which stands for Digital Multiplex.

**DMX universe:** Represents 512 DMX channels. Enough for 170 RGB LEDs (1 LED takes 3 channels, one for red, one for green and one for blue).

**FPS:** Frames per second. It refers to an output rate for video or DMX.

**KiNet:** Protocol to transmit DMX over a standard Ethernet network. Designed by Color Kinetics.

**LED strip/string:** Lighting fixture that may contain many LED elements and have a certain physical length. Some LED strips are flexible and can be bent to create curves and all kind of shapes. ELM handles all lighting fixtures as if they were strips, giving you a lot of positioning flexibility.

**Mapping:** Mechanism used to associate a pixel from a media source to a specific lighting fixture element.

**Media:** Any type of visual content, including videos and pictures.

**Network Device Interface (NDI):** Protocol to stream live videos over the network. Developed by NewTek - <http://NDI.NewTek.com>.

**Open Sound Control (OSC):** Network protocol allowing multimedia apps to communicate. ELM can be remotely controlled via OSC.

**RGB, RGBW, RGBA, RGBWA:** Various color components: red, green, blue, white and amber.

**sACN:** Protocol to transmit DMX over a standard Ethernet network - like Art-Net. More specifically, the E1.31 subset is used for DMX control. Developed by ESTA.

**Spout:** Real-time video sharing framework for Windows. Similar to Syphon on Mac. <http://spout.zeal.co/>

**Stage:** A mapping surface defining the position of the media placeholder and the position of lighting fixtures.



## Getting Started With LED Strips

ELM can control any DMX-enabled lighting fixtures – not only LED strips. This is made possible because ELM outputs industry standard protocols like Art-Net, sACN and KiNet. This means that ELM can control traditional DMX dimmers and any RGB, RGBW, RGBA and RGBAW lighting fixtures. It's also possible to control complex fixtures like moving heads.

Controlling LED strips is a little bit different than traditional DMX fixtures. The main difference is that you need to use LED controllers to drive your strips. They replace the Art-Net nodes you use for traditional DMX fixtures. The LED controller receives DMX via Art-Net/sACN and converts to the special protocol the LEDs understand. Enttec offers the Pixelator which takes 48 DMX universes and controls up to 8160 RGB LEDs.

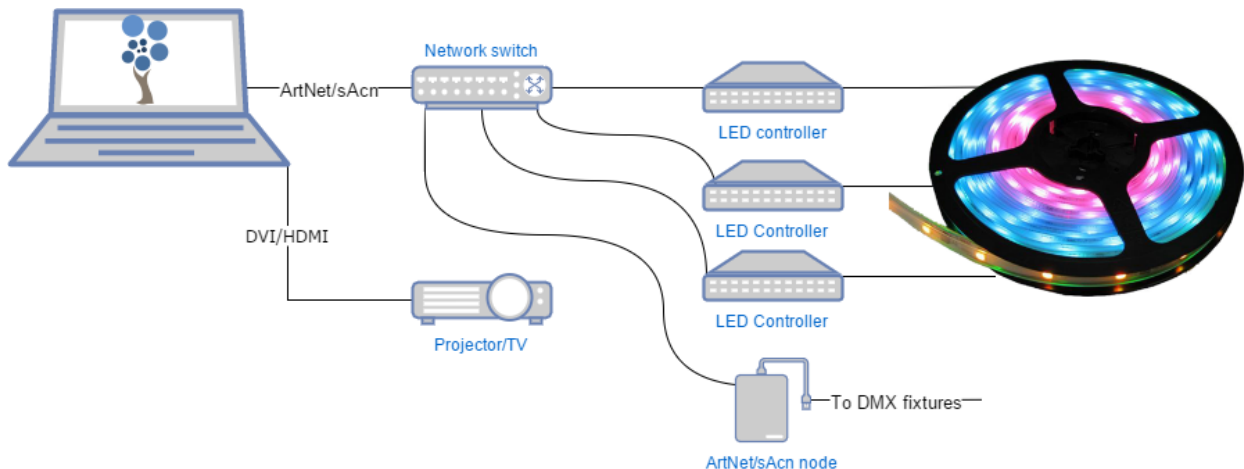

The next step is to get LED strips and DMX fixtures. Since there are many LED protocols out there, you need to make sure your LED controller fits with your LEDs. Common protocols for RGB LEDs are WS2811 and WS2812/B. For more information about getting compatible LEDs, contact your Enttec representative. Here's the Enttec Pixelator that can be used to control the Phero and Enttec LED tapes:





## Quick Overview

ELM allows dividing your installation into multiple zones and layers called stages. You control the media content independently for each stage. Stages can overlap and they are merged (blended) to generate the final result. A common scenario is to create a stage spanning the whole installation to map media across the board. To enable precise control over specific zones, you create smaller stages inside the big stage. Then you activate these zones whenever you want. For example, in the installation below, we can play a video on the overall stage - which acts as the background layer - and when there's a special event, we activate the logo zone and make it flash.

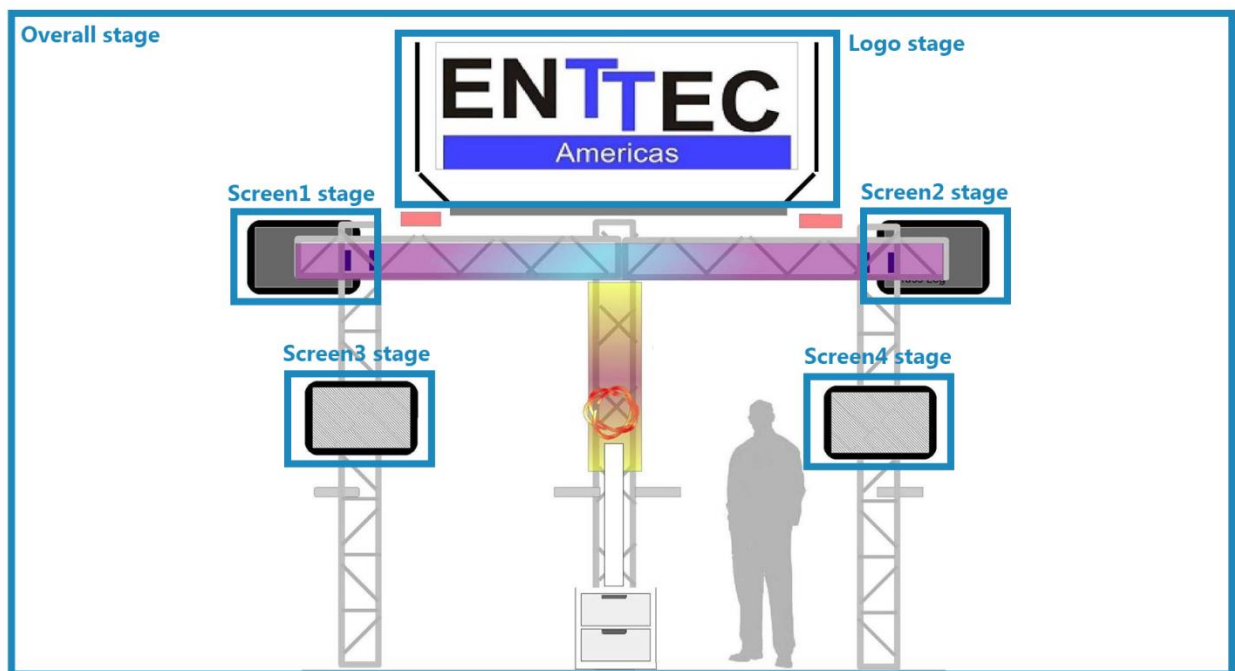

To represent your LED strips and DMX fixtures inside a stage, ELM has a powerful vector-based editor. This way, you can easily draw many types of shapes, including matrices, loops and curves. ELM computes the position of each LED based on your drawing.

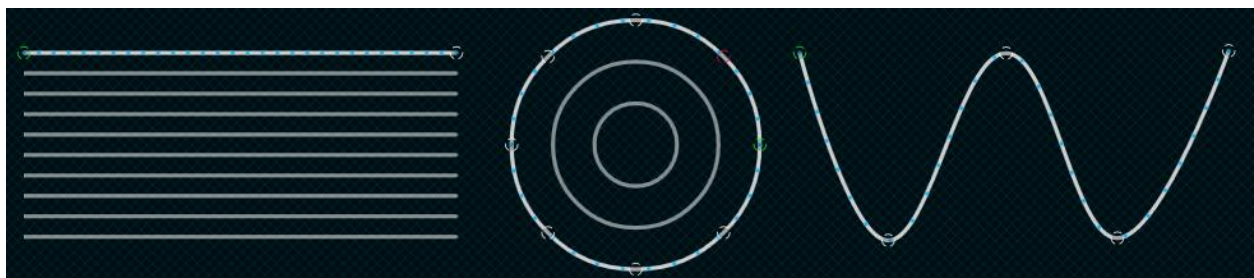



## ELM Tour

Let's go over the main screens and controls of ELM.

### Home Screen

Welcome! Start a new project or load an existing one. To see the keyboard shortcut keys, press the alt key.

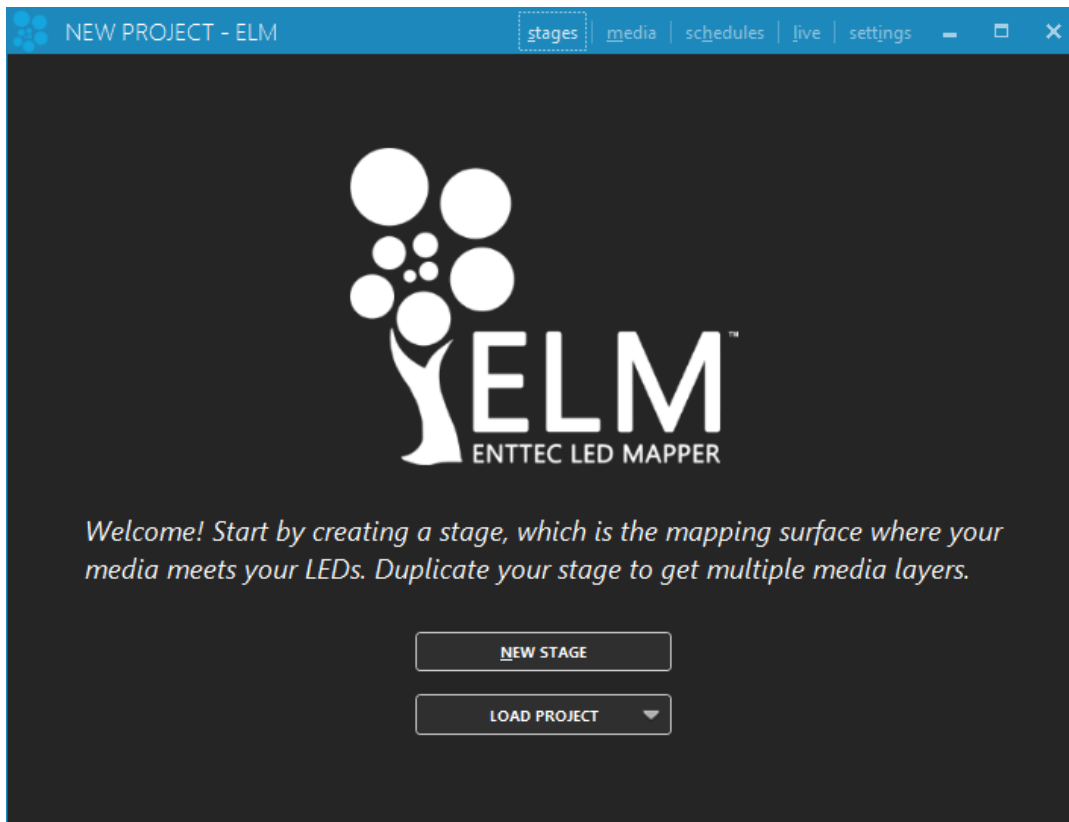

<b>New stage (alt-N)</b>	Creates your first stage and start the mapping process.
<b>Load project (ctrl-O)</b>	Loads an existing project.
<b>Recent projects (down arrow)</b>	Loads a recent project. Click on the down arrow in the load project button to show the list.
<b>Media (alt-M)</b>	Goes to the media library.
<b>Schedules (alt-H)</b>	Goes to the schedules.
<b>Live (alt-L)</b>	Goes to the live panel.
<b>Settings (alt-I)</b>	Goes to the settings panel.



## New Stage Dialog

A rule of thumb is to create a stage with dimensions respecting the aspect ratio of your media. Then you'll position your LED strips on it to create the mapping. For example, you can create a full HD stage - which has a rectangular aspect ratio - to fit your media sources, and then map a 20x20 square LED array on it.

You can easily change the dimensions later, so don't worry. The minimum recommended size is 320x180. Smaller than this size, you'll need to constantly work at a very high zoom level, which isn't very convenient. So it's better to use a higher size and let ELM scale your media.

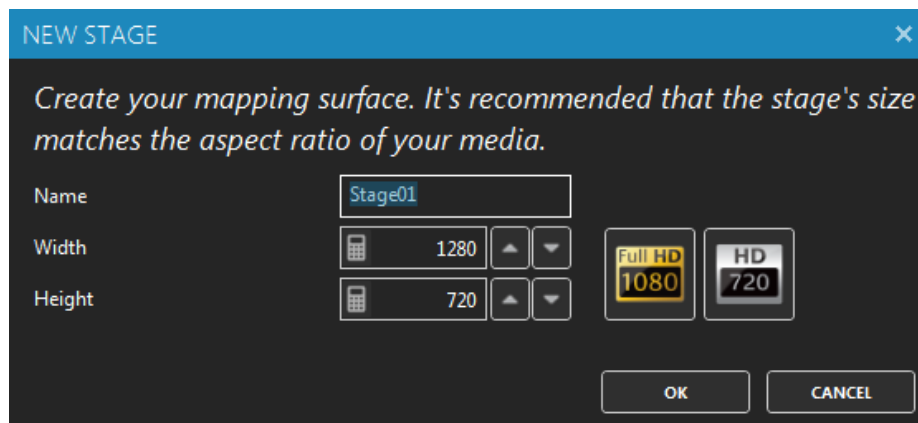

<b>Name</b>	The name of your new stage. Usually refers to its physical location.
<b>Width, Height</b>	The desired size in pixels for the mapping surface used to display media. This can be changed later without affecting the mapping.
<b>Full HD, HD buttons</b>	Presets for common media sizes. Full HD is 1920x1080 and HD is 1280x720.

*To help you position the strips like they are in the real world, use a picture of your installation as the stage's background (see Stage Tab). No pictures handy? Use your phone's camera to get one!*

---



## Stages

Shortcut key: alt-S

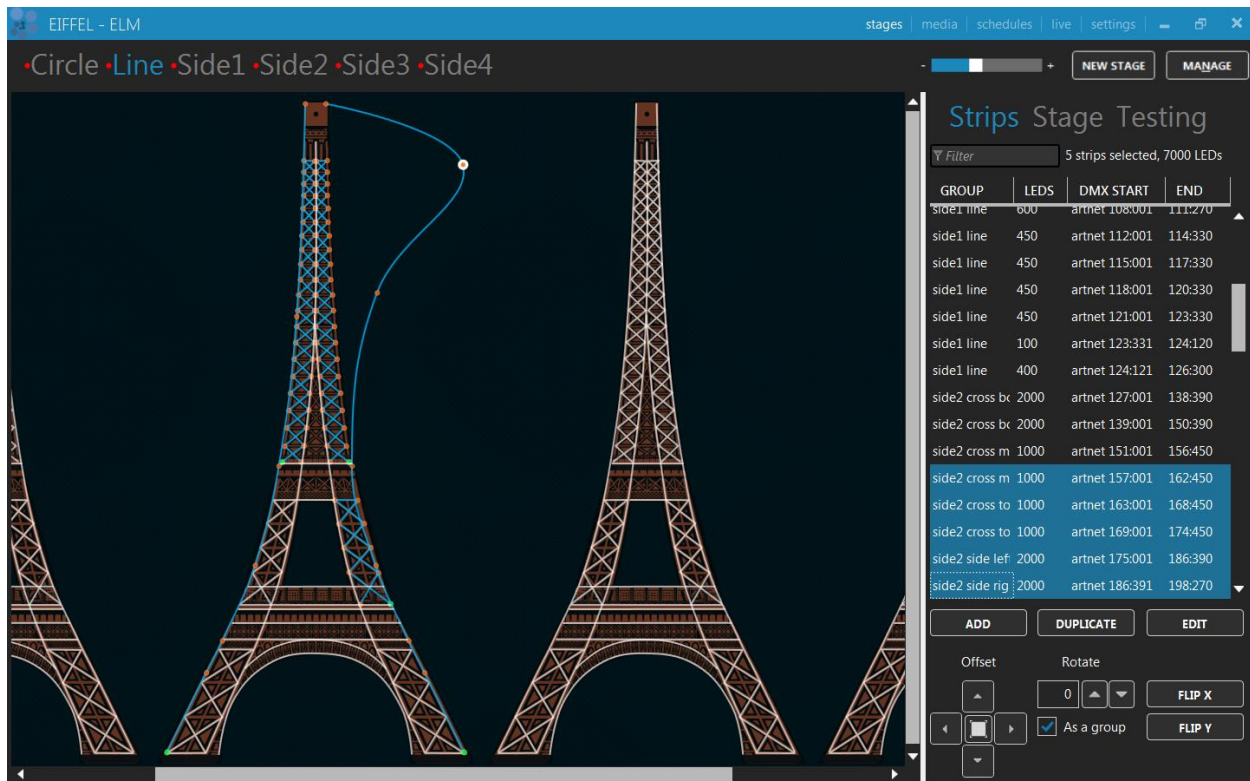

You can create as many stages as you want. Generally, you'll want an overall stage corresponding to the whole installation and multiple individual stages to target specific zones. The overall stage allows you to map content across the board. Then the other stages allow you to override specific parts of your installation whenever you want. You can select the current stage by clicking its name at the top.

***Different effects may demand different mapping layouts. One goal of the mapping is to ease the content creation. So don't hesitate creating multiple stages with the same LED strips but positioned in different ways.***



## Status Indicator

At the left of the stage's name, a small indicator tells you the current control mode and its status. The activated status means a media is selected and the stage's intensity (see Live Mode) is greater than 0%.

• Stage	Manual control mode, stage deactivated.
Stage	Manual control mode, stage activated.
R Stage	Remote control mode, stage deactivated.
R Stage	Remote control mode, stage activated.
S Stage	Schedule control mode, stage deactivated.
S Stage	Schedule control mode, stage activated.
A Stage	The audio reactive mix mode is active.
T Stage	The testing mode is active.

## Stage Syncing

All stages using the same media slot are considered to be synced. You can still change the individual stage output parameters like the intensity and the color filter, but the media content is the same on all synced stages. When applicable to the media type, the media playback speed is determined by the maximum speed of all stages using this media.

***To play the same video file on multiple stages but at different speeds, load the video file in multiple media slots. Then use a different media slot for each stage.***

---



## Stage Merging and Layering

When multiple stages contain the same LED strips, a merge occurs following the order as shown in the Stages Manager. This allows creating complex visuals by layering multiple stages on top of each other. You can target specific zones by creating stages with only a subset of all strips or with parts of the strips outside the stage. A stage must be activated (a media is selected and the stage's intensity is greater than 0) otherwise it is considered to be transparent and will not be part of the merge.

The merge modes are:

<b>Overwrite</b>	Completely replaces the left stages. The right stage is fully opaque.
<b>Multiply</b>	Multiplies each pixel of the right stage with the corresponding pixel for the left stage. The right stage becomes a video mask.
<b>Screen</b>	The values of the pixels in the two stages are inverted, multiplied, and then inverted again. This yields the opposite effect to Multiply. The result is a brighter picture.
<b>Overlay</b>	Combines Multiply and Screen modes. The parts of the right stage where left stage is light become lighter, the parts where the left stage is dark become darker.
<b>Darken</b>	Takes the smallest color component for each pixel.
<b>Lighten</b>	Takes the largest color component for each pixel.
<b>Difference</b>	Subtracts the left stage from the right stage or the other way round, to always get a positive value.
<b>Add</b>	Adds pixel values of one stage with the other.
<b>Subtract</b>	Subtracts pixel values of the right stage to the left stage.
<b>Black key</b>	Shows the pixels of the left stage only where the pixels of the right stage are black. In other words, black pixels are transparent.
<b>IntensityCrossFade</b>	The stage's intensity determines its opacity level.
<b>IntensityWhiteFade</b>	The stage's intensity determines its opacity level in a white fade fashion, meaning that when the intensity is at 50%, both the current stage and the ones under are merged at full opacity.

***To easily target specific zones of an installation, first create the overall mapping then select the strips corresponding to the individual zones and right-click in the strip list to access the "new stages from strips" menu.***



## Edit Zone

You can position your strips as they are in the real world or based on the effect you want to create with your media.

A strip has start (green) and end (red) control points indicating the direction of the patch. Multiple intermediate control points can be used to create various shapes. You can bundle multiple strips together to simplify the handling of complex shapes.

You can position parts of your strips outside the stage. In this case, the LEDs outside the stage will not be mapped. This is a common scenario when using the same strips in multiple stages and you want to target specific parts in each stage.



<b>Select strips/Deselect all (ctrl-d)</b>	Click a strip to select. Hold the ctrl key to add to the selection. Hold shift to use a selection window and select all strips inside the rectangle. Press ctrl-a to select all strips and ctrl-d to deselect.
<b>Move a control point</b>	Click on a control point and drag it. Hold shift while dragging to align with the previous point.
<b>Move selected strips</b>	Right-click on a strip and drag it or use the move handle at the top-left corner of the selection. You can also use the ctrl-keyboard arrows.
<b>Add a control point</b>	Right-click on the stage (only one strip needs to be selected) or on a control point to use the context menu.



<b>Delete a control point</b>	Right-click on a control point and select the delete option.
<b>Bundle/Unbundle strips (ctrl-b, ctrl-shift-b)</b>	Select multiple strips and right-click on one of them in the Strip List. Then select the bundle menu item to create one element with all selected strips. You can unbundle the strips to edit or see the details.
<b>Move around the stage</b>	Click on the stage background and drag.
<b>Zoom in/out (ctrl-plus, ctrl-minus, ctrl-0, ctrl+mousewheel)</b>	Use the zoom control at the top. Zoom out when you want to offset the selected strips quickly. Ctrl-0 resets the zoom.
<b>Show individual LED positions</b>	When zoomed enough, the LEDs of the selected strips should be visible. They are the blue dots. Put your mouse over to see the LED number and its DMX address.
<b>Copy/paste strips (ctrl-c ,ctrl-v)</b>	Copy and paste the selected strips. You can paste the strips in a different stage.
<b>Delete selected strips (ctrl-delete)</b>	To delete the selected strips, use the ctrl-delete shortcut or right-click in the strip list and select the delete menu item.
<b>Undo (ctrl-z), Redo (ctrl-y)</b>	You can always use Undo and Redo while editing.
<b>As a group</b>	This checkbox under the rotate section determines whether strips are rotated, moved and scaled all together, maintaining the overall shape or if the action is done to each strip individually. This doesn't apply when using the move, rotate and resize handles. For example, if you uncheck this option and enter 0 in the X position box, all strips will move to the position 0.



## Strips Tab

Shortcut key: alt-P

### Strip List

GROUP	LEDS	DMX START	END
side1 cross bottc	300	artnet 000:001	001:390
side1 cross bottc	300	artnet 001:391	003:270
side1 cross midc	100	artnet 003:271	004:060
side1 cross midc	100	artnet 004:061	004:360
side1 arch small	100	artnet 004:361	005:150
side1 line	100	artnet 005:151	005:450

The strips for the current stage are shown in this list. Select one or multiple strips in the list to also select them in the edit zone. Right-click in the list for more options. You can click the column headers to sort. Type text in the filter box to filter based on the group names.

***Use the group and sub-group fields wisely in order to use the filter box and quickly select the strips you want.***

---

### Add Strips Dialog (Patching)

Shortcut key: alt-A

Quickly patch your strips and lighting fixtures to create arrays and any shapes you can imagine. Multiple LED types (or color types) are supported, including RGB, RGBW, RGBA, RGBAW/RGBWA and white (dimmers) in multiple configurable color temperatures like WWA. Most color component orders (GRB, BGR, etc.) are supported. For lighting fixtures supporting high precision colors, 16 bit color depth can be used via the RGB16, GRB16, RGBA16, RGBW16 and White16 types. RGBWmax activates all channels (RGB+white) when white is needed for maximum brightness.



ADD STRIPS
✕

Number of strips  ▲ ▼

LEDs per strip  ▲ ▼

Type RGB ▼

Shapes lines ▼

Group group sub-group

DMX protocol ArtNet ▼

Start universe  ▲ ▼

Start address  ▲ ▼

LED address offset  ▲ ▼

Break universe after  ▲ ▼ strips ▼

ADD
CANCEL

<b>Number of strips</b>	The number of LED strips/fixtures you want to patch.
<b>LEDs per strip</b>	The number of LEDs per strip. Enter 1 to create a unique fixture.
<b>Type</b>	Also named pixel type. Corresponds to the color component order (RGB, BGR, GRB, etc.) and the capability (white only, RGBW, etc.). Many LED strips have the color components in a different order than red, green and blue. Usually, LED controllers have the option to reorder the color components but ELM can handle this for you.
<b>Shapes</b>	Select a predefined shape (lines, arches, circles, triangles, hexagons, etc.) to position your strips on the stage. For arrays, use lines. Remember that you can create any kind of shapes by adding control points later.
<b>Patching direction</b> 	For LED arrays, specify the way your strips are wired to let ELM automatically assigns the proper DMX addresses.
<b>Group and sub-group</b>	Use these two groups to tag your strips and quickly find them later. You can search for these keywords in the strip list's filter box.
<b>DMX protocol</b>	Select the output method for DMX: Art-Net, sACN or KiNet. Select none to leave the strips un-patched at the moment and not output any DMX.



<b>Start universe</b>	The universe of the first strip to be patched.
<b>Start address</b>	The DMX address of the first strip to be patched.
<b>LED address offset</b>	ADVANCED The number of DMX channels between the start of two consecutive LEDs. Increase it to leave holes between your LEDs/fixtures, allowing merging ELM's output with another console. For example, you can control moving heads by letting ELM handles the colors and a console handles the movement.
<b>Break universe after</b>	ADVANCED Automatically start patching in the next universe when reaching this limit (number of strips of LEDs). Set to 0 to break only when the universe is full.

*You've got the patching direction wrong? No problem. You can easily flip your strips horizontally and vertically later. For snake mode, right-click in the strip list and use the select odd/even option.*

---

*Want to control more complex DMX fixtures like moving heads? Let say your moving head has 20 channels and the RGB channels start at 3. In ELM, patch it with a start address of 3 and a LED address offset of 20. ELM will send 0 for the unused channels, which allows merging the DMX data from ELM with the DMX data from a console. The console should provide the values for the pan and tilt and the all other channels except the RGB.*

---

*Whites! You can get a more accurate preview by using the right type of white LED type. Use the WhiteCool, WhiteNeutral, WhiteWarm and WWA (cool, neutral and warm whites) LED types. Unlike the White LED type which takes the perceived brightness of the media as its value, you get finer control with the other whites.*

---



## Pixel Types

LED Type	Detail	Remark
<b>RGB, RBG, BGR, BRG, GBR, GRB</b>	Red, green and blue.	
<b>RGBW, GRBW</b>	Red, green, blue and white.	The white is automatically activated based on the saturation of the media color. The less saturated the color is, the more the white LED is activated. As the white is activated, the RGB LED levels are reduced proportionally until only the white LED is active for a pure white color.
<b>RGBWmax</b>	Red, green, blue and white.	The white activation is calculated like for RGBW but the RGB LEDs aren't reduced proportionally. The result is that when a pure white color is needed, all RGBW LEDs are activated. While it gives a maximum brightness, it also takes more power.
<b>RGBA</b>	Red, green, blue and amber.	The amber LED is automatically activated the closer the media color is to amber. As the amber is activated, the RGB LED levels are reduced proportionally until only the amber LED is active for a pure amber color.
<b>RGBAW, RGBWA</b>	Red, green, blue, amber and white.	The white and amber LEDs are activated following the same recipe as for RGBW and RGBA.
<b>White</b>	White or one color component only.	The activation level is based on the perceived brightness of the media color (using the luma calculation).
<b>WhiteCool</b>	White cool.	Special type of cool white LED that you can use to get a more accurate preview in the stage monitor. The activation is based on the blue level of the media color.
<b>WhiteNeutral</b>	White neutral.	Special type of neutral white LED that you can use to get a more accurate preview in the stage



		monitor. The activation is based on the green level of the media color.
<b>WhiteWarm</b>	White warm or amber.	Special type of warm white LED that you can use to get a more accurate preview in the stage monitor. The activation is based on the red level of the media color.
<b>WWA</b>	White cool, white neutral and white warm/amber.	There are 3 types of whites and you'll get an accurate preview in the stage monitor. The white cool activation is based on the blue level of the media color, the neutral on the green and the warm on the red.
<b>WAW</b>	White cool, white warm/amber and neutral white.	See WWA.
<b>AWW</b>	White warm/amber, neutral white and white cool.	See WWA.
<b>...16</b>	High resolution 16-bit per color component.	All types ending with 16 are the 16-bit version of the LED type. For example, RGB16 takes 6 DMX channels, 2 for red, 2 for green and 2 for blue. While it takes more channels, it gives smoother color transitions and more headroom for color corrections.

For the color temperature settings to get a more accurate stage monitor preview, see Colors.



## Duplicate Strips Dialog

Shortcut key: alt-D

Copy the selected strips and create new strips by applying certain transformations.

<b>Number of duplicates</b>	The number of times you want to copy the selected strips.
<b>Group and sub-group</b>	Use these two groups to help you quickly find your strips later. When creating multiple duplicates, the primary group will automatically be appended with a counter.
<b>Universe offset</b>	The offset used to calculate the first DMX universe of the newly created strips.
<b>Address offset</b>	The offset used to calculate the first DMX address of the newly created strips.
<b>X offset</b>	The horizontal position offset applied to the newly created strips.
<b>Y offset</b>	The vertical position offset applied to the newly created strips.



<b>Rotate offset</b>	The rotation in degrees applied to the newly created strips.
<b>Rotate center, offset X, offset Y</b>	The position where the rotation will occur and how to offset the rotation center (for example, to leave a hole in the middle of the rotated strips).

*When you're in the design phase of the lighting installation, keep in mind the duplicate options. They allow creating complex shapes by copying simple elements. This is a real time saver.*

---

*To make sure certain strips always stay together, use the bundle feature. You can create complex shapes by combining multiple simple elements. See the bundle/unbundle options in the Edit Zone.*

---

*To copy strips to another stage, select your strips and use the copy (ctrl-c) and paste (ctrl-v) keyboard shortcuts. You can also right-click in the Strip List to see all options.*

---



## Edit Strips Dialog

Shortcut key: alt-E

Edit the selected strips and allow changing the patch.

<b>LEDs per strip</b>	The number of LEDs per strip.
<b>Type</b>	The pixel type. See Add Strips Dialog (Patching).
<b>Segments</b>	Determines whether it's straight lines or curves between the points. Curves are perfect to represent flexible strips.
<b>Closed shape</b>	Determines whether you want a closed shape like a square.
<b>1<sup>st</sup> LED position</b>	For closed shape, you can move the first LED around the shape to be exactly where the first LED is in reality.
<b>Group – primary, secondary</b>	Use these two groups to help you quickly find your strips.
<b>Stabilizer</b>	Takes the average of the media pixels around the LEDs to reduce large jumps. May be used like an Ambilight feature.
<b>Levels (alt-L)</b>	Adjusts the intensity, temperature and tint to compensate for manufacturing and age differences.
<b>DMX protocol</b>	Select the output method for DMX. For example, Art-Net or sACN E1.31.
<b>Start universe</b>	The universe of the first strip to be patched.
<b>Start address</b>	The address of the first strip to be patched.
<b>LED address offset</b>	See Add Strips Dialog (Patching).
<b>Break universe after</b>	See Add Strips Dialog (Patching).



<b>Apply DMX changes to other stages</b>	Executes your DMX changes on the matching strips in other stages. It is handy when you have copied the same strips in multiple stages in order to keep them in sync.
<b>Locate (alt-C)</b>	Locates each LED in the real world by going through a list.
<b>Re-Patch (alt-P)</b>	Forces redoing the patch to make sure all selected strips are patched one after another.
<b>Reverse LEDs (alt-R)</b>	Reverses LEDs without changing the shape. This is handy when the strip has been physically installed in the wrong direction.
<b>Split (alt-S)</b>	Splits the strip in two and allows each part to be configured independently.
<b>Join (alt-J)</b>	Joins all selected strips one after another to form only one strip.

### **Offset/Resize Strips Dialog**

Shortcut key: alt-O

Precisely change the position and size of the selected strips.

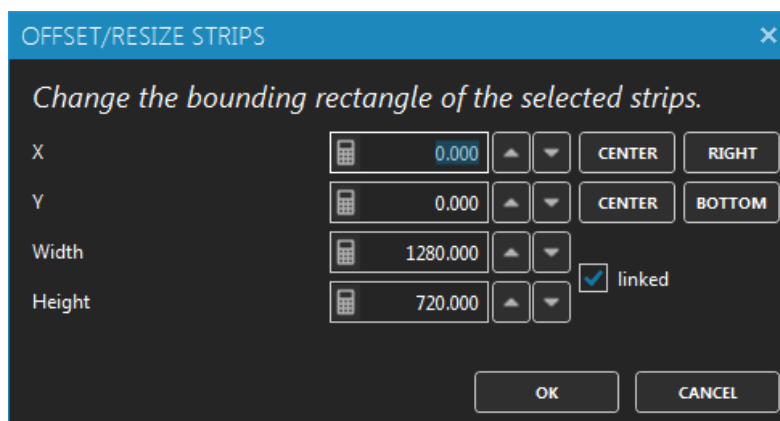

<b>X</b>	The position of the left boundary of the rectangle. A value of 0 means the far left of the stage.
<b>Y</b>	The position of the top boundary of the rectangle. A value of 0 means the top of the stage.
<b>Width</b>	The horizontal length.
<b>Height</b>	The vertical length.
<b>Linked option</b>	When checked, the initial aspect ratio is preserved when changing the width or height.

***Right-click in a numeric box and move the mouse left/right to quickly change the value.***



## Stage Tab

Shortcut key: alt-g

<b>Size</b>	The mapping size of the stage. Change it with the resize button.
<b>Preview opacity</b>	Determines the visibility of the preview. You can disable the preview to save CPU by setting the opacity to 0.
<b>Schedules/Live</b>	Controls how this stage appears in the schedules and live views. You can hide it or make it read-only.
<b>Background image</b>	To help you position the LED strips like in the real world, you can display an image on the background of the stage.
<b>Offset, scale and rotate</b>	Allows positioning the background image where you want.
<b>Opacity</b>	Determines the visibility level of the background image.
<b>Sticky notes</b>	Puts notes anywhere on the stage to remember key points of the mapping and TODOs.
<b>Snap strip points (ctrl-P)</b>	Snaps control points to help positioning.
<b>Grid (ctrl-G)</b>	Configure the snap to grid feature by specifying size of a cell in pixels. Use the offset X-Y to align the top-left cell with your design.
<b>Monitor (alt-O)</b>	Opens a monitor window to help you see the final result of the mapping.
<b>LED snapshot</b>	Exports a PNG image showing the exact position of every LED. This is useful for motion designers as they can use the snapshot as a content guide.

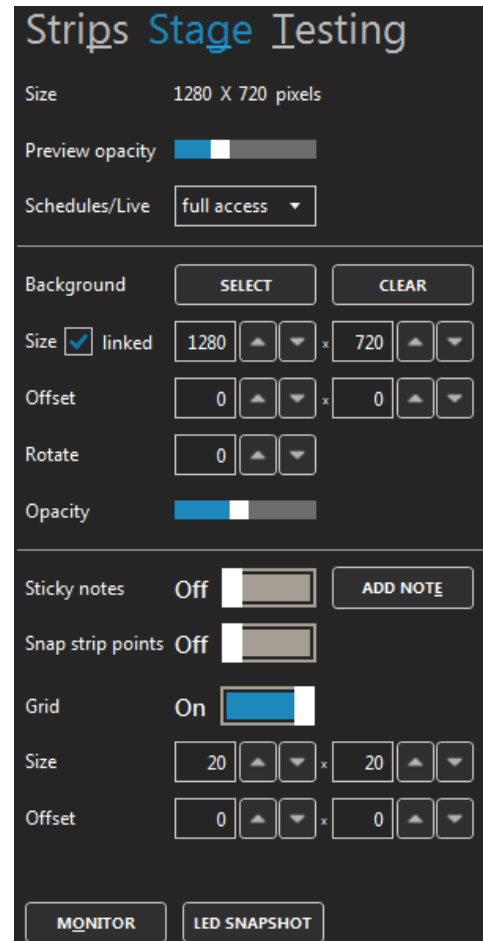



***When you are editing and zoomed in very closely, if a media is playing in the preview, your computer may have a hard time. To help it, disable the preview by setting the preview opacity to 0%.***

---

Here's the monitor window. You can see the result of the stage only or after all stages have been merged. When you don't have access to the real fixtures, this is an indispensable tool while creating effects. Alternatively, you can use any 3<sup>rd</sup> party visualizer able to receive the LED rendering via NDI (see NDI output in the Stages Manager) or supporting Art-Net or sACN.

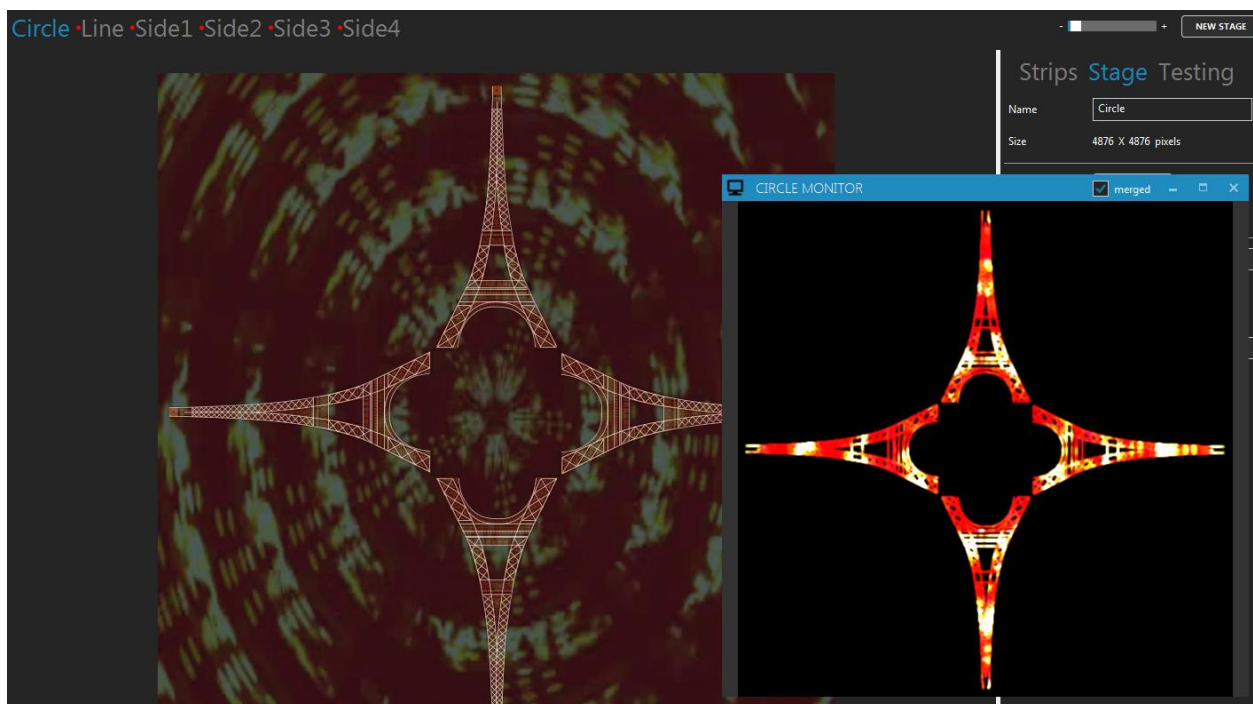

***Try reducing the stage's size and see if the output is still good. Also reduce your videos and other media size accordingly to potentially save a lot of CPU. High resolution media is not always a good thing!***

---



## Testing Tab

Shortcut key: alt-T

Quickly test the mapping by generating a rectangle that you can move over the strips.

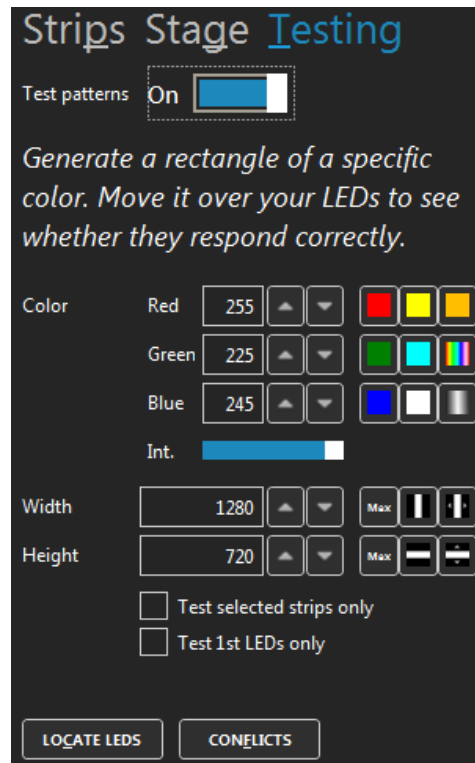

<b>Test patterns On/Off switch</b>	Activates the generation of test patterns.
<b>Color</b>	Changes the color of the testing rectangle. It is handy to test the color component order of your strips.
<b>Width, Height</b>	Changes the size of the testing rectangle.
<b>Test selected strips only</b>	If checked, only the selected strips in the Strips Tab will be under test. The other strips will all be off.
<b>Test 1<sup>st</sup> LEDs only</b>	Only test the 1 <sup>st</sup> LEDs of each strip to better see where each strip starts.
<b>Locate LEDs</b>	Locates each LED in the real world by going through a list. Alternatively, you can put the mouse over a LED in the editor. The LED number and its DMX address are displayed which is handy to count the LEDs and troubleshoot addresses.
<b>Conflicts</b>	Analyzes all patched LEDs of the current stage and looks for overlapping DMX addresses. In some situations you may want to have duplicated LEDs on the stage but if this isn't the case, you should adjust the DMX addresses.



***Reduce the width and height of the testing rectangle and drag the rectangle around the stage. This way, you can see if the patch order is right. For example, if dragging the rectangle from left to right makes the LEDs go on from right to left, then you know you need to flip them horizontally. To do so, go in the Strips Tab and click the Flip X button.***

---

***Quickly test the red, green and blue component order of your LEDs by generating a pure red, pure green and pure blue test. For each test, note the color of your LEDs. If you're not getting a RGB order, edit your LED strips and select the LED type corresponding to the order you've observed (BGR, GRB, GBR...).***

---

***While the testing mode is active, the DMX is constantly being outputted at the full output rate, even when there's no change. This is handy while you're configuring your LED controllers and want to see if it's working. This is also a good way to test whether your network supports the load.***

---

***Use the "test selected strips only" option, go in the Strips Tab and change the selection in the strip list. This is similar to traditional lighting consoles locate function.***

---



## Stages Manager

Shortcut key: alt-N

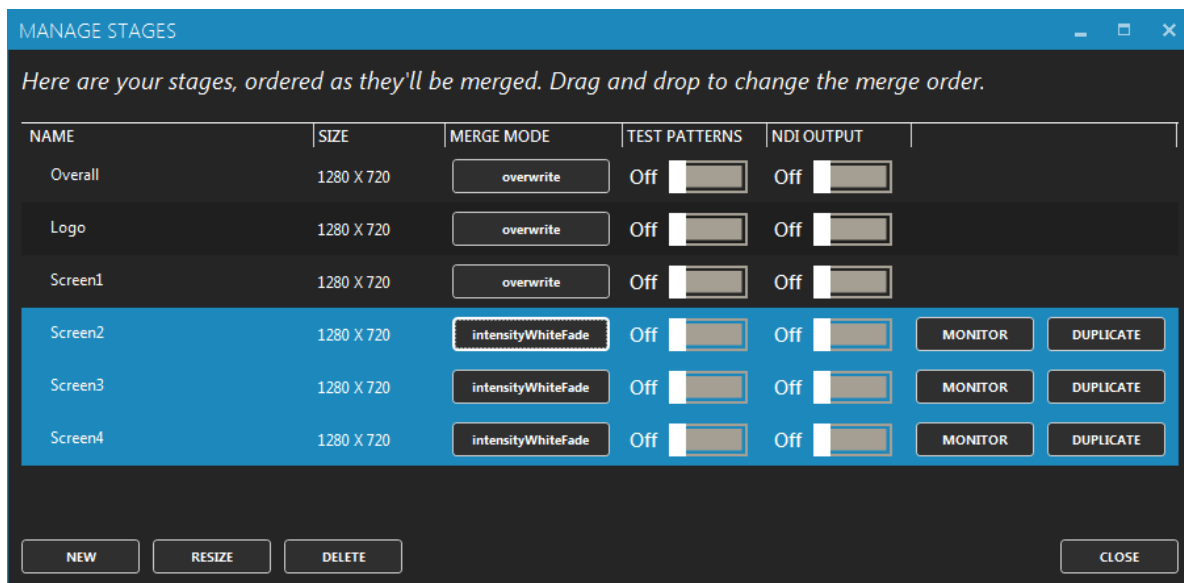

Select multiple stages in the list to modify them all at once. The first stage of the list is the bottom media layer and the following stages can override any preceding stages. Drag and drop stages to reorder.

<b>Name</b>	The name of the stage. Select a stage to edit its name.
<b>Size</b>	The size in pixels of a stage.
<b>Merge mode</b>	Specifies how the values are merged when multiple stages target the same LEDs. The merge starts with the stage at the top of the list. You can reorder the stages with drag and drop. See Stage Merging and Layering for more details.
<b>Testing</b>	Activates the testing mode.
<b>NDI output</b>	Stream the LED rendering via NDI to be used by 3D visualizers like WYSIWYG, Capture or Realizzer. This way you don't need to patch your LEDs in the visualizer and you get a very high quality and live LED rendering.
<b>Monitor</b>	Opens a monitor window to help you see the final result of the mapping for this stage.
<b>Duplicate</b>	Copies the stage to get a new media layer.
<b>New</b>	Creates a new stage.
<b>Resize</b>	Resizes all selected stages.
<b>Delete</b>	Deletes all selected stages.



## Media Library

Shortcut key: alt-M

You can manage your media and see what's active. Up to 255 media items can be loaded.

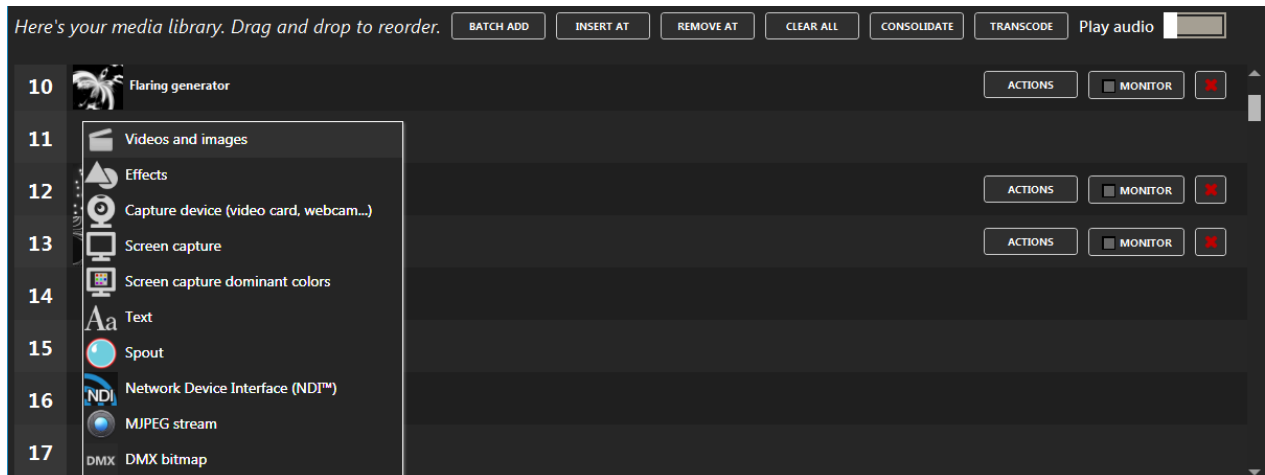

<b>Batch add (alt-A)</b>	Loads multiple video and picture files at once.
<b>Insert At, Remove At</b>	Inserts or removes a slot and offsets other media accordingly.
<b>Clear all</b>	Resets the library.
<b>Consolidate</b>	Copies all files in the same directory to make it easy to move your project file to another computer.
<b>Transcode</b>	Transcodes multiple videos at once. Converts to a MPEG4 format that should play on all computers. Also adjust contrast and brightness.
<b>Play audio</b>	For videos, plays the audio track if available.
<b>Playback position indicator</b>	For videos, shows the position and allows seeking, which is handy for long videos to test specific parts.
<b>Actions</b>	Depending on the media, you can rename a file, replace the media and duplicate it.
<b>Monitor</b>	Opens a window showing the images coming from a media source. Can also set a custom media thumbnail.
<b>Delete button</b>	Clears a media slot and allows selecting another media.
<b>Swap items and reorder</b>	You can swap items by using drag and drop.



### **Video Files (with or without audio)**

Most video formats are supported when the appropriate DirectShow video codecs are installed. By default, ELM can play these files: .mov, .avi, .wmv, .mpeg, .mp4, .mp2, .mkv, .webm, .ogv and .ogg. There's no video size and resolution limits. The audio track is played back on the default sound device. If not needed, you can remove the audio by using the transcode button.

The recommended video format is MPEG4 in an avi file. For smaller files at the expense of a higher CPU usage, you can use H264 in an avi file.

### **Picture Files**

Use images like bmp, jpeg, gif (animated or not) and png.

### **Effects**

The built-in effects give you pixel-perfect and configurable visuals. There are 100+ effects available, each one configurable in multiple ways. Many effect parameters are controllable via the DMX remote.

### **Capture Devices**

Use live videos captured with a video card input or a connected camera like a webcam. Any DirectX/DirectShow compatible hardware and software are supported.

### **Screen Capture**

Capture any part of your screen and use it as a media in ELM. For example, play a video on Youtube and map it to your LEDs. Another utility is to capture your video editor (like Adobe After Effects) preview zone and let ELM generate a LED preview in real-time to assist your content creation. This avoids having to render your video before trying it in ELM.

### **Screen Capture Dominant Colors**

Capture any part of your screen and extract the dominant colors. This is useful to do color matching between any kind of content and your LEDs.

### **Texts**

Generate scrolling text with various fonts.

### **Spout (v. 2.006)**

Use live videos generated by the most common video frameworks and VJ software. This includes Resolume, Ableton Live, Processing, Max/Msp, TouchDesigner, Cinder, OpenFramework, VVVV, Isadora, After Effects, Mapio, Unity3D and more. The Spout integration gives you total control over the content and is the way to go when you want interactive visuals.





### **Network Device Interface (NDI v. 4.1)**

Receive live video streams via the network, as commonly used in professional live show productions. Easily connect ELM to a multitude of NDI compatible hardware and software, including capture cards, IP cameras and video over the cloud. NDI has been developed by NewTek - <http://NDI.NewTek.com>.



### **MJPEG Streams**

It's the most basic way to receive video streams via the network. If your IP camera doesn't support the more complete NDI protocol, it should at least support MJPEG streaming.

### **DMX Bitmap**

This special media allows receiving DMX from a lighting console and convert it to a video. You can then use this video like any other media and map it on your LEDs. A common usage scenario is to control groups of LEDs with one RGB or intensity value.

***To quickly test your installation without having the final videos, just use the built-in effects. You can create your schedules and test everything right away. Then when you'll get your videos, replace the built-in effects.***

---

***Media file paths are saved relatively to your project file. Use the consolidate feature to copy all files in a directory next to your project. Then copy everything to your other computer.***

---



## Schedules

Shortcut key: alt-H

Each stage has its own schedule. A schedule can contain as many playlists as you need and you trigger them with an activation time, date range and day of week.

The screenshot shows the 'Stage01' configuration window. On the left, a table lists playlists:

STATUS	PLAYLIST	ACTIVE	START TIME	DURATION
▶ 00:01:55	Default	Everyday	Midnight	00:02:15/loop
	Night	Everyday	Sunset+02:00:00	00:15:00

The right pane shows a detailed view of a playlist with the following columns:

STATUS	MEDIA	DURATION	MAX PLAY COUNT	MAX PLAY TIME(S)	COLOR
▶ 00:00:08 1x	06	00:00:05	<input type="checkbox"/>	15.0	Cyan
	07	00:00:05	<input type="checkbox"/>	15.0	White
	08	00:00:05	<input type="checkbox"/>	15.0	White
	09	00:00:05	<input checked="" type="checkbox"/>	15.0	Orange
	01	00:00:05	<input checked="" type="checkbox"/>	15.0	Orange
	02	00:00:05	<input checked="" type="checkbox"/>	15.0	Orange
	03	00:00:05	<input type="checkbox"/>	15.0	White

Below the table are controls for 'ADD MEDIA', 'DELETE', 'Start time' (0:0:0 relative to Midnight), 'Duration' (Auto, Loop), 'Start/end dates' (jan 1 to dec 31), 'Active days' (Su, Mo, Tu, We, Th, Fr, Sa), and 'Transitions' (crossfade, 2.0 s, Intensity level, Speed 1.0 x).

<b>Add playlist (alt-P)</b>	Creates a playlist for the current stage.
<b>Rename playlist</b>	Right-click on a playlist to see the menu or double-click on its name.
<b>Copy/Paste playlist</b>	Right-click on a playlist to see the menu.
<b>Stop during daylight</b>	Stops this stage's schedule during daylight hours. Based on the sunset and sunrise times.
<b>Scheduler On/Off</b>	Temporarily stops all schedules. It is handy to take over and manually select what's playing on each stage in the live mode. This option isn't saved to the project file.
<b>Sunrise, Sunset times</b>	Computed based on your location. See Time.

Select a playlist to see its settings. Double click to play. The playlist settings are:

<b>Add media (alt-A)</b>	Adds one or multiple media to the playlist.
<b>Delete</b>	Removes the selected items from the playlist.
<b>Start time</b>	The time of the day to start the playlist.
<b>Relative to</b>	Determines how to interpret the start time.



<b>Duration</b>	The duration of the playlist (end time).
<b>Loop</b>	Repeats the playlist indefinitely (loop).
<b>Start and end dates</b>	The date range (inclusive) when the playlist is active.
<b>Active days</b>	The days of the week when the playlist is active.
<b>Transitions</b>	The type and duration of transition effects, from the classic crossfade to complex effects rotating and scaling the media. If color filters are used, a nice transition will also occur between the colors.
<b>Intensity level</b>	The luminosity level (dimmer). Set to 0 to deactivate the stage.
<b>Speed</b>	The playback speed. Does nothing for live video streams.

Drag and drop media items in the list to reorder. Select one or multiple items and right-click to see the menu, allowing copying and pasting items across playlists. The settings for each media item are:

<b>Status</b>	The playing status, indicating the playing time and number of repetitions done.
<b>Media</b>	The associated media. Click to change it.
<b>Duration</b>	For some types of media like video, displays the total play time.
<b>Max play count</b>	The maximum number of times to play this media before playing the next one.
<b>Max play time</b>	The maximum number of seconds to play this media before playing the next one.
<b>Color filter</b>	The RGB color filter to apply to the media. White means no filter.

If “infinite time” is displayed for the status of an item that means this item will play indefinitely or until the playlist ends (if the playlist duration is specified). Specify a max play time if this isn't what you want.

***Turn off the scheduler to temporarily take control of what's playing on your stage using the live mode.***

---

***Select multiple media items to change them all at once when modifying the play count, play time and color filter.***

---



## Live Mode

Shortcut key: alt-L

The main goal of the live mode is to see what's playing on each stage and configure the effects. For example, if a playlist is running, you'll see what's happening in real-time, including the transitions. If nothing is controlling the stage, you'll be able to manually select what's playing.

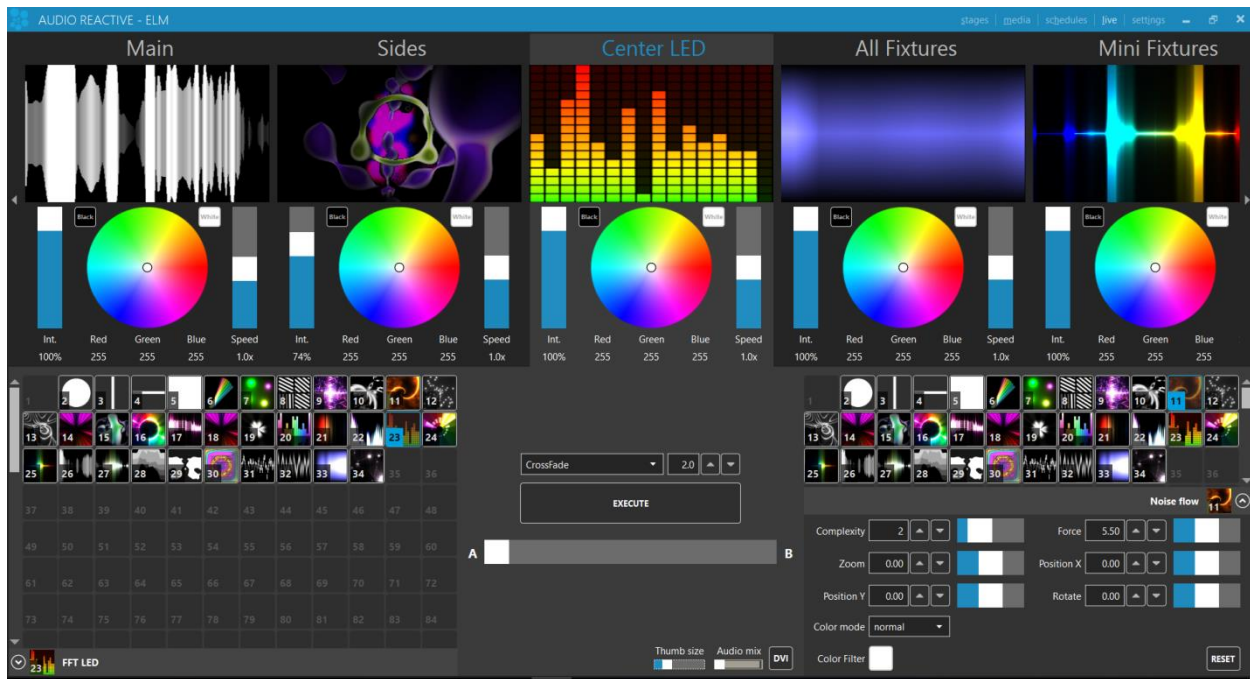

<b>A and B media banks</b>	Shows the loaded media. Click a media to select it.
<b>A and B configuration panels</b>	At the bottom of the right and left sides, the selected media are displayed and you can expand the sections to see the parameters of the media.
<b>A-B Fader</b>	Mix the media from the A and B sides, using the selected transition/mix effect.
<b>Execute</b>	Automatically creates a transition from A to B or B to A depending on the most active side.
<b>Transition effect and duration</b>	Selects one of the 40+ transition/mix effects and its duration in seconds.
<b>Intensity</b>	The luminosity level (dimmer). Set to 0 to deactivate the stage.
<b>Color wheel</b>	Filters the color output. It works like a color gel, where if you select the red color, only red pixels will be visible at the output.
<b>Speed</b>	The playback speed. Used for certain media types only, including video files, built-in effects and texts. Does



	nothing for live video streams.
<b>Thumb size</b>	Determines the size of the media thumbnails in the A and B media banks.
<b>Audio reactive mix</b>	Automatically mixes your media in sync with the music. It's a kind of auto-pilot, which is handy to create a show very quickly. Click the "... " button to select the audio input.
<b>DVI</b>	Opens a window to output the video to a projector or TV. The position of the window is saved in the project file. You can output the media or the LED map. The LED map is exactly the size of the stage and one LED is exactly one pixel. This is required for systems taking a video input like Martin P3.

***You can use ELM to output video to a projector or TV without controlling LEDs. Simply create a stage and don't put any LEDs on it. Then in the live mode, click the DVI button.***

---

***Using black and white media allows you to use the color filter and get exactly the RGB color you want as output.***

---

***Use the live mode as a monitor to help you see what's going on while remotely controlling ELM with another lighting console. You can also open multiple DVI outputs (one per stage) and use them as monitors.***

---



## Settings

Shortcut key: alt-I

### Project

This is the overall panel, displaying the most important info about your project status.

<b>New project</b>	Closes the current project and start a new one.
<b>Load (ctrl-o)</b>	Opens an existing project.
<b>Save as</b>	Saves the project under a new name.
<b>Save (ctrl-s)</b>	Saves the project.
<b>Import</b>	Imports items from another project, including stages, media and DMX settings.
<b>Export patch</b>	Creates an html file containing all strips/fixtures to be opened in a web browser or Excel.
<b>Firewall</b>	Does the necessary firewall configuration for all network protocols. ELM must be running as administrator.
<b>DMX universes</b>	The number of DMX universes used by your project. This is the number used to calculate your license limit (if any).
<b>Stages</b>	The number of stages in your project.
<b>Strips</b>	The number of strips in all stages.
<b>Mapped LEDs</b>	The number of LEDs inside the mapping zones in all stages (including duplicated LEDs).
<b>Output rate (fps)</b>	The number of times per second DMX packets are sent. Default is 30, max 120. WARNING! Don't set it higher than what your LED controllers/fixtures support. This may result in DMX packets being discarded and visual artefacts.
<b>DMX output</b>	Activates or temporarily disables the DMX output. This is handy during testing.
<b>Lock stages</b>	Prevents accidentally editing the stages by requesting a password to unlock (last 4 characters of the hardware ID).
<b>Run at startup</b>	Automatically runs ELM when Windows starts and loads the last opened project file.

A project backup file is created every 5 minutes. To avoid slowdown during a live show, you need to manually save the project to trigger the backup creation. To open a backup, select the Backup file type in the file browser when opening a project. To set the backup to be the current project, simply save the project.



## Art-Net

Settings for the Art-Net universes.

<b>Adapter</b>	Selects a network adapter for the output.
<b>Universe display</b>	By default, universes are in the hexadecimal format, where the first digit is the Net (0 or 1) followed by the Sub-Net (0-F) and then the universe (0-F). In decimal mode, the universes are displayed from 0 to 511.
<b>Scan nodes</b>	Opens a window and shows the detected Art-Net nodes. Click the configure unicast button to activate Art-Net unicast and send the universes to the subscribed nodes.
<b>Locate uni.</b>	Locates universes by sending all channels at full. No LEDs need to be patched.
<b>Monitor</b>	Shows the exact DMX values being sent.
<b>Optimize frames</b>	When activated, universes are sent only when there's a change and only the channels that have changed are sent, which may considerably reduce the network load. Older or low-powered nodes may not support it.
<b>ArtSync</b>	When activated, sends a ArtSync packet after all universes have been sent. This makes sure all outputs to the lights are in sync and prevents tearing problems.
<b>Universe IP addresses</b>	For each universe, enter an IP address to enable unicast and send the DMX packet to a specific node. Type broadcast to send the universe to all connected nodes in the network. Unicast is preferred when using more than 64 Art-Net universes or a WiFi network.

## sACN

Settings for the sACN universes.

<b>Adapter</b>	Selects a network adapter for the output and the input if using remote control with sACN.
<b>First universe</b>	Since sACN supports thousands of universes, set the first universe to use.
<b>Priority</b>	Selects the priority level used for merging multiple sACN data sources. This is useful when using two ELM computers and you want to use one as a backup by setting its priority to a lower level than the main computer.
<b>Locate uni.</b>	Locates universes by sending all channels at full. No LEDs need to be patched.
<b>Monitor</b>	Shows the exact DMX values being sent.
<b>Optimize frames</b>	When activated, universes are sent only when there's a



	change, which may considerably reduce the network load.
<b>sACN Sync</b>	When activated, sends a sync packet after all universes have been sent. This makes sure all outputs to the lights are in sync and prevents tearing problems. The sACN controllers need to support sACN sync.
<b>Universe IP addresses</b>	For each universe, enter an IP address to enable unicast and send the DMX packet to a specific node. Type multicast to send the universe to all subscribed nodes in the network. Unicast is preferred when using more than 64 sACN universes with a network switch not IGMP v2 ready or a WiFi network.

### KiNet

Settings for the Philips Color Kinetics devices (power supplies). The protocol version is KiNet v2 (PORTOUT). You map each KiNet device's port to a universe in ELM. You can map up to 2048 ports. Use Philips QuickPlay Pro to configure and get the IP addresses of your KiNet devices.

<b>Adapter</b>	Selects a network adapter for the output.
<b>Locate uni.</b>	Locates universes by sending all channels at full. No LEDs need to be patched.
<b>Monitor</b>	Shows the exact DMX values being sent.
<b>Device IP addresses</b>	Enter the IP address of your device.
<b>Port</b>	Enter the destination port for each device (1-16).

### Audio

Activate and configure up to 8 audio inputs. The audio inputs are used by the audio reactive effects and the audio reactive mix. Activate the loopback input to listen to what's playing on this computer.

<b>Activation switch</b>	Determines whether this audio input is activated. Deactivate unused inputs to save resources.
<b>Volume</b>	Adjusts the input volume.
<b>Falloff speed</b>	Adjusts how fast the frequency bands go down.
<b>Lower/higher frequencies (Hz)</b>	Adjusts the frequency range to be used for the audio analysis.
<b>Up/down arrows</b>	Moves the audio input to another slot. This way if the position of an audio source changes, you'll not need to update all your audio reactive effects.
<b>WaveIn/ASIO</b>	Switch between the standard Windows Audio and the low latency ASIO modes.



## Time

Settings for accurate sunrise and sunset times, automatically updated throughout the year based on your location.

<b>Your position</b>	Your latitude and longitude position on Earth. You can also select a preset in the list.
<b>Offsets (minutes)</b>	Offsets the sunrise and sunset times. For example, if you want to start the installation 2 hours before sunset, you enter (-120) in the sunset box.
<b>Test helpers</b>	Temporarily modifies the current time and date to help you test your schedule. These values aren't saved in the project file.

## Colors

Adjust the color temperature and intensity of the various LED types in order to get a more accurate preview in the stage monitor. This is particularly important when you're using LEDs with multiple types of whites. For example, the WWA LED type is composed of the cool white, neutral white and warm white (or amber). Adjusting any of these whites will change the appearance of the WWA LEDs in the stage monitor.

## License

Manage your licenses. You can import multiple licenses to get more DMX universes.

<b>Backup</b>	Saves your license file in case you need to reinstall your OS.
<b>Import</b>	Imports a license file.
<b>Hardware ID</b>	Your unique computer's ID, used to generate the licenses.



## Remote Control

ELM can be remotely controlled in many ways. Multiple inputs can be active at the same time to give you even more flexibility. The DMX input always takes priority.

### *DMX – Art-Net, sAcn and Enttec USB Pro*

Settings for remotely controlling ELM with a lighting console.

<b>Input mode</b>	Selects how you want to remote control ELM. The current options are Art-Net, sACN and a Enttec USB Pro interface.
<b>Network adapter</b>	For Art-Net only, you can select a different network adapter for output and input.
<b>Universe</b>	Selects the DMX input universe.
<b>Monitor</b>	Shows the exact DMX values being received.
<b>Address</b>	Selects the DMX address for the first stage.
<b>Fixture mode</b>	Selects the level of control you want (Basic or Extended).
<b>DMX value mode</b>	Percent: makes it easy for consoles working in percent. Raw: makes it easy for consoles working in the 0-255 DMX range.
<b>Media remote</b>	Maps DMX channels to be used to remotely control the media parameters.

The DMX sheet showing what can be controlled and by which channel is integrated in ELM. It is dynamically generated based on the current remote settings and your stages. This way, you can't lose it!

When no DMX data is received for more than 5 seconds, the remote control mode will automatically be deactivated. This is a failsafe feature in case the remote console has a problem. When this happens, the schedule resumes right away. If there are no schedules, then the current media will continue to play.



### Basic Fixture Mode (8 channels per stage)

Channel	Name	Values	Note
1	Remote control mode	0: Remote control deactivated 1-254: Reserved, don't use 255: Remote control activated	Remote control activated only when receiving 255. 0 disables the remote control mode and the stage goes back to being controlled via the schedule (if any) or manually.
2	Media index	0: No function 1-99: Media index	The media to play. If needed, a transition (crossfade) is automatically executed between the current media and the new one. This effectively controls the A and B sides in the live panel for you.
3	Intensity level	0: Stage deactivated 1-255: Level	The output level (dimmer). When at 0%, the stage is considered to be deactivated and doesn't override stages with a lower precedence anymore - it becomes transparent. To keep the stage activated and force a black output, use the color filters at 0%.
4	Red filter	0-255	Filters the color output.
5	Green filter	0-255	Filters the color output.
6	Blue filter	0-255	Filters the color output.
7	Playback speed	0: Paused 1-255: Speed up to 10x. 25 = 1x	For some type of media like videos, effects and texts, the speed controls how fast the playback goes. For live streams, the speed has no effect.
8	Transition duration	0: No transition 1-255: Duration up to 20 seconds. 12 = 1s.	When transitioning between media, this controls the duration of the crossfade.



### **Extended Fixture Mode (15 channels per stage)**

Channel	Name	Values	Note
<b>1</b>	Remote control mode	0: Remote control deactivated 1-254: Reserved, don't use 255: Remote control activated	Remote control activated only when receiving 255. 0 disables the remote control mode and the stage goes back to being controlled via the schedule (if any) or manually.
<b>2</b>	Intensity level (MSB/coarse)	0: Stage deactivated 1-65535: Level	The output level (dimmer). When at 0%, the stage is considered to be deactivated and doesn't override stages with a lower precedence anymore - it becomes transparent. To keep the stage activated and force a black output, use the color filters at 0%.
<b>3</b>	Intensity level (LSB/fine)		
<b>4</b>	Red filter	0-255	Filters the color output.
<b>5</b>	Green filter	0-255	Filters the color output.
<b>6</b>	Blue filter	0-255	Filters the color output.
<b>7</b>	Media A speed	0: Paused 1-255: Speed up to 10x. 25 = 1x	For some type of media like videos, effects and texts, the speed controls how fast the playback goes. For live streams, the speed has no effect.
<b>8</b>	Media B speed	0: Paused 1-255: Speed up to 10x. 25 = 1x	For some type of media like videos, effects and texts, the speed controls how fast the playback goes. For live streams, the speed has no effect.
<b>9</b>	Media A index	0: Empty 1-99: Media index	The media to play on side A.
<b>10</b>	Media B index	0: Empty 1-99: Media index	The media to play on side B.
<b>11</b>	Media mixing position (MSB/coarse)	0-65535 0: media A fully active 65535: media B fully active	Controls the position of the mixing effect, from A to B.
<b>12</b>	Media mixing position (LSB/fine)		



<b>13</b>	Mixing position modifier	0: No function 1-255: Various mapping functions	Spices up the mixing position by applying a function like bounce, sigmoid and exponential. See the list of functions in ELM.
<b>14</b>	Mixing effect	0: no effect 1: crossfade 2: black fade 3: white fade 4-255: Various effects	Determines the effect to be applied when mixing the A and B sides. From simple crossfade to complex effects including rotations, scaling and translations. See the list of effects in ELM. When not needed, select the 'no effect' to avoid wasting CPU.
<b>15</b>	Reserved (unused)		

### ***CITP/MSEX***

Activate this option to enable ELM to communicate with other CITP/MSEX compatible consoles and software. CITP/MSEX version 1.0, 1.1 and 1.2 are available. The things ELM can do are:

- Send the media thumbnails to your console
- Stream the LED preview of every stage to your console or visualizer
- Send the stage statuses, including the current playing media



## OSC

Settings for remotely controlling ELM via OSC (Open Sound Control) over the network. ELM listens for incoming OSC on all network adapters.

```

/elm/stages/{stage name}/
  live/
    intensity          0..1
    rgb                0..1, 0..1, 0..1
    media              0..99
    speed              0..10
    transitionFx       0..43
    transitionDuration 0..9999 seconds
    audioMixControlled {0: no, 1: yes}
    remotelyControlled {0: no, 1: yes}
  mix/
    position          0..1
  A/
    media              0..99
    speed              0..10
  B/
    media              0..99
    speed              0..10

scheduler/
  running              {0: no, 1: yes}
  playlists/{playlist name}
    running             {0: no, 1: yes}

```

Addresses and names are case-insensitive.

Media index 0 is an empty slot.

RGB can be sent in 3 parts at the /r /g and /b addresses.

audioMixControlled: controls the audio mix activation.

remotelyControlled: determines whether OSC overrides the scheduler.

Use \* (wildcard character) in the stage name to target multiple stages at once. For example, /elm/stages/\*XYZ targets all stages.

/elm/stages/background\*XYZ targets all stages with a name starting with background.



## HTTP

Settings for remotely controlling ELM via HTTP, which is a protocol based on TCP/IP. This is the most reliable way to integrate ELM with control systems like Crestron and Pharos or to create custom web interfaces. ELM listens for incoming HTTP requests on all network adapters.

Request	Parameters	Output
GET /elm/status		statuses of all sub-systems like under the settings/project menu
GET /elm/heartbeat		200 OK if the server is running
GET /elm/stages	includeState 0 (only names) 1 (ids, names and other info)	list of stages
GET /elm/stages/{stage name or id}		Stage id, name and other info
GET /elm/stages/transitionFxNames		list of all transitionFx names
GET /elm/stages/{stage name or id}/live		state of the requested stage
POST /elm/stages/{stage name or id}/live	intensity 0..1 media 0..99 speed 0..10 transitionFx {name}, transitionDuration 0..9999 red 0..255 green 0..255 blue 0..255 audioMixControlled 0 or 1 remotelyControlled 0 or 1	activate the audio mix mode if 0, let the scheduler or another remote takes over.
GET /elm/stages/{stage name or id}/patch		list of all patched strips
GET /elm/stages/{stage name or id}/monitor	width. height, fps	MJPEG stream of the LED preview
GET /elm/stages/{stage name or id}/scheduler		state of a scheduler
POST /elm/stages/{stage name or id}/scheduler	running 0 (no) or 1 (yes) RGBRemotelyControlled 0 or 1 intensityRemotelyControlled 0 or 1	starts/stops the scheduler overrides the scheduler's RGB overrides the scheduler's intensity
GET /elm/stages/{stage name or id}/scheduler/playlists	includeState 1 (return playlist states)	list of playlist names
GET /elm/stages/{stage name or id}/scheduler/playlists/{playlist name}		state of a playlist
POST /elm/stages/{stage name or id}/scheduler/playlists/{playlist name}	running 0 (no) or 1 (yes)	starts/stops the playlist
GET /elm/media/slots	includeState 1 (return slot states)	list of filled media slot ids
GET /elm/media/slots/{id}		state of a media slot
GET /elm/media/slots/{id}/thumbnail	width, height	PNG image
GET /elm/media/slots/{id}/monitor	width. height, fps	MJPEG stream of the media
POST /elm/media/slots/{id}	path (load an existing local file) form file (upload a new file)	state of the updated media slot

For example, to start the playlist "playlist01" of the stage "stage01", the request is:

```
POST /elm/stages/stage01/scheduler/playlists/playlist01?running=1 HTTP/1.0\x0D\x0A
Content-Type: application/x-www-form-urlencoded\x0D\x0A
Content-Length: 0\x0D\x0A
\x0D\x0A
\x0D\x0A
```



To get the info about this playlist, the request is:

```
GET /elm/stages/stage01/scheduler/playlists/playlist01 HTTP/1.0\r\n\r\n\r\n
```

Notes:

- Each line ends with `\r\n` characters which are in hexadecimal `\x0D\x0A`.
- There are two empty lines at the end of a request.
- Use `*` (wildcard character) in the stage name to target multiple stages at once for POST.
- All data is returned in JSON.
- Use the returned HTTP status code to do proper error handling.
- Addresses and names are case-insensitive.
- Parameters can be provided in the query string or form data.
- Media id 0 is an empty slot.

The base URL to access the API is: **`http://YOUR-COMPUTER-NAME:port/elm`**. If you prefer, you can replace the computer name by its IP address or localhost if the server is running on the same computer. The port can be omitted if it's 80, which is the default for HTTP.

You can restrict the access to the API by activating the Basic Auth feature. For more details see [https://en.wikipedia.org/wiki/Basic\\_access\\_authentication](https://en.wikipedia.org/wiki/Basic_access_authentication).



## Troubleshooting

### Output - Art-Net/sACN/KiNet

Problem	Possible causes	Solutions
<b>No Art-Net nodes detected in the scan nodes dialog.</b>	<p>The node IP address may be incorrectly configured. For example, the computer's IP is 192.168.1.X and the node's IP is 192.168.0.Y.</p> <p>The wrong network adapter may be selected in ELM.</p> <p>The firewall is blocking ELM.</p>	<p>Change the IP address of your computer or your node to be on the same network, that is most of the time, the 3 first numbers need to be the same. The subnet masks (netmask) also need to be the same. Usually, you want to use 255.255.255.0 as the subnet mask.</p> <p>Go under the settings menu and make sure the proper network adapter is selected for each DMX protocol.</p> <p>Use the firewall button in ELM.</p>
<b>Output lag/shuttering (working but with intermittent delays).</b>	<p>The network is overloaded, most of the time due to the use of broadcasting. By default with Art-Net, all universes are broadcasted (sent to all connected devices on the network). Some routers and switches may have problems under heavy load. With sACN, multicast is used and may not be well supported by your routers and switches, resulting in broadcasts.</p>	<p>Enter your node IP addresses in the universe boxes to enable unicast sending. For Art-Net, click the scan nodes button and then the configure unicast button (see Art-Net). This greatly reduces the work your router/switch has to do.</p> <p>Alternatively, you can lower the ELM's output rate (see Project).</p> <p>Another way to reduce the network load is to enable the optimize frames option.</p>
<b>Some lights wrongly stay on for half a second or so.</b>	<p>The most common cause is an unreliable network like a WIFI causing data packets to be discarded.</p> <p>Missed DMX packets due to a too high output rate and the optimize frames option being ON.</p>	<p>Disable the optimize frames option for Art-Net or sACN. ELM will continuously send data even when there's no change. You may need to reduce the output rate to avoid network overload.</p> <p>When the optimize frames is ON, ELM doesn't send DMX unless there's a change. So if your LED controller or</p>



		<p>fixture discards a packet because it's overloaded, visual artifacts will be visible. Try deactivating the optimize frames option or reducing the ELM's output rate.</p>
<p><b>The lights do nothing.</b></p>	<p>The nodes may not be properly configured or not plugged.</p> <p>The strips may be configured to use the wrong universes and/or addresses.</p> <p>The firewall may be blocking ELM.</p>	<p>Test the nodes with the configuration utility from the manufacturer. Check the IP address configuration as described above.</p> <p>Check the universes and addresses of your strips. You can use an Art-Net sniffer like the Artnetominator or Wireshark to see what ELM is sending.</p> <p>Disable your firewall. Use the locate universe feature in ELM to force sending all channels at full.</p>
<p><b>The lights flicker.</b></p>	<p>The most common cause of flickers when using LED strips is that the wrong LED type or protocol has been configured in the LED controller. For example, selecting TM1803 instead of WS2811.</p> <p>Maybe some LEDs don't have enough power. It can cause flickers at the end of the strips.</p> <p>This may also be caused by using video content with little noise in it due to compression (may not be problematic when displayed on a screen but it becomes apparent on LEDs).</p> <p>Some older LED fixtures may not work well when using the Art-Net optimize frames option.</p>	<p>Start your LED controller configuration utility and check the configured LED type. Try different types if you're unsure.</p> <p>Enable the testing mode (see Testing Tab) and select a low brightness color. This will cause the LEDs to use less power. If the flickers go away, then the problem is due to not having enough power going to the LEDs. You'll need to inject more power.</p> <p>The testing mode generates a pure color, so if this isn't a power problem and a full white test color doesn't cause flickers, that means the video content is probably the problem.</p> <p>Disable the optimize frames option (see Art-Net).</p>



## General

Problem	Possible causes	Solutions
<b>ELM isn't starting and saying a dll is missing.</b>	Probably the Visual Studio 2015 run-time component is missing.	Download and install the Visual C++ Redistributable for Visual Studio 2015 <a href="https://www.microsoft.com/en-ca/download/details.aspx?id=48145">https://www.microsoft.com/en-ca/download/details.aspx?id=48145</a>
<b>Very high CPU usage.</b>	<p>The computer can't handle your videos.</p> <p>You are looking at a stage and the computer is having a hard time drawing pretty graphics.</p> <p>The output rate is too high.</p>	<p>Reduce the resolution of your videos by using the transcode button (see Video Files). Transcoding can convert to an easier to decode format which may also save CPU.</p> <p>If you're using live video capture, try reducing the capture resolution.</p> <p>If the computer is already overloaded, try not to unnecessarily leave ELM on a graphic heavy screen. Minimize the ELM window or go in the setting/project tab. Also make sure to close all monitor windows.</p> <p>Alternatively, you can lower the ELM's output rate (see Project).</p>
<b>When moving my project to another computer, the media are missing.</b>	The ELM project file doesn't contain the media and the stage's background images.	You need to move the media to the other computer and put them at the same place relatively to the project file. A good practice is to create a media folder next to your project file. Alternatively, use the consolidate feature of the media library (see Media Library).
<b>I see a blank screen when using a remote desktop app like LogMeIn or VNC.</b>	The ELM user interface uses hardware acceleration (DirectX and OpenGL). Some remote desktop app doesn't support it or need special configuration.	You may need to configure your remote desktop app to support hardware acceleration. Alternatively, TeamViewer works well with ELM.
<b>The eye candy effects aren't working on Mac under Parallels.</b>	ELM needs OpenGL 3.3 and Parallels only supports OpenGL 3.2.	Use Bootcamp instead of Parallels.



## EULA

This End-User License Agreement (EULA) is a legal agreement between you (either an individual or a single entity) and the mentioned author and copyright holder (Lightjams inc.) and distributor (Enttec LLC) of this Software for the software product identified above, which includes computer software and may include associated media, printed materials, and “online” or electronic documentation (“SOFTWARE PRODUCT”).

By installing, copying, or otherwise using the SOFTWARE PRODUCT, you agree to be bounded by the terms of this EULA.

If you do not agree to the terms of this EULA, do not install or use the SOFTWARE PRODUCT.

### SOFTWARE PRODUCT LICENSE

1. GRANT OF LICENSE. This EULA grants you the following rights: Installation and Use. Each license is registered to one person and covers the use of the SOFTWARE PRODUCT on one or multiple computers depending on the license type, so long as multiple computers are not used at the same time. The license is locked to the computer’s CPU and motherboard.

### 2. DESCRIPTION OF OTHER RIGHTS AND LIMITATIONS.

Limitations exist on Reverse Engineering, Decompilation, Disassembly and changing (adding, deleting or modifying) the resources in the compiled assembly of the SOFTWARE PRODUCT. You may not reverse engineer, decompile, or disassemble the SOFTWARE PRODUCT, except and only to the extent that such activity is expressly permitted by applicable law notwithstanding this limitation.

### Updates and Maintenance

ELM updates are FREE of charge.

### Separation of Components.

The SOFTWARE PRODUCT is licensed as a single product. Its component parts may not be separated for use on more than one computer.

### Software Transfer.

You may not rent, lease or sublicense the SOFTWARE PRODUCT on a temporary or permanent basis.



#### Termination.

Without prejudice to any other rights, the Author of this Software may terminate this EULA if you fail to comply with the terms and conditions of this EULA. In such event, you must destroy all copies of the SOFTWARE PRODUCT and all of its component parts.

### 3. COPYRIGHT.

All title and copyrights in and to the SOFTWARE PRODUCT (including but not limited to any images, photographs, clipart, libraries, and examples incorporated into the SOFTWARE PRODUCT), the accompanying printed materials, and any copies of the SOFTWARE PRODUCT are owned by the Author of this Software (Lightjams inc). The SOFTWARE PRODUCT is protected by copyright laws and international treaty provisions. Therefore, you must treat the SOFTWARE PRODUCT like any other copyrighted material.

#### LIMITED WARRANTY

##### NO WARRANTIES.

The Author of this Software expressly disclaims any warranty for the SOFTWARE PRODUCT. The SOFTWARE PRODUCT and any related documentation is provided "as is" without warranty of any kind, either express or implied, including, without limitation, the implied warranties of merchantability, fitness for a particular purpose, or noninfringement. The entire risk arising out of use or performance of the SOFTWARE PRODUCT remains with you.

##### NO LIABILITY FOR DAMAGES.

In no event shall the author of this Software be liable for any special, consequential, incidental or indirect damages whatsoever (including, without limitation, damages for loss of business profits, business interruption, loss of business information, or any other pecuniary loss) arising out of the use of or inability to use this product, even if the Author of this Software is aware of the possibility of such damages and known defects.